

<sup>TM</sup>  
**Ethernet Pocket Hub** <sup>TM</sup>  
**Model 0403**  
**(E-TBT-HB-0403)**

7356.C

For assistance in installing, using, or  
maintaining the TRANSITION Networks  
Model 0403 Ethernet Pocket Hub,  
contact TRANSITION Networks  
Technical Support at:

**(800) 260-1312**

or contact your local distributor.

---

## Compliance Information

UL Listed

### FCC Regulations

This equipment has been tested and found to comply with the limits for a Class A digital device, pursuant to Part 15 of the FCC Rules. These limits are designed to provide reasonable protection against harmful interference when the equipment is operated in a commercial environment. This equipment generates, uses, and can radiate radio frequency energy and, if not used in accordance with the instruction manual, may cause harmful interference to radio communications. Operation of this equipment in a residential area is likely to cause harmful interference in which case the user will be required to correct the interference at his own cost.

### Canadian Regulations

This digital apparatus does not exceed the Class A limits for radio noise for digital apparatus set out on the Radio Interference Regulations of the Canadian Department of Communications.

### Copyright Restrictions

© 1995 TRANSITION Networks Inc.

All rights reserved. No part of this work may be reproduced or used in any form or by any means – graphic, electronic, or mechanical – without written permission from TRANSITION Networks Inc.

### Trademark Notice

All registered trademarks and trademarks are the property of their respective owners.

---

The sole purpose of this remedy shall be provided the customer with the replacement or repair of non-conforming goods in the manner described in this Warranty statement. This exclusive remedy shall not be deemed to have failed of its essential purpose so long as TN is willing and able to repair or replace the defective item(s) or refund the purchase price.

TN reserves the right to inspect products claimed to be defective under warranty either at the customer's location or at TN's plant. TN assumes no liability for liability charges incidental to the adjustment, service, repairing, removal or replacement of the product, or other costs, or the expense of repairs made outside of its factory, except when made with TN's prior written consent. Additionally, Transition Networks reserves the right to charge for all testing and shipping incurred, if after testing, a return is classified as "No Problem Found".

TN's total liability in connection with the products and their installation to all persons and from all causes in the aggregate, whether in contract, tort, or strict liability, shall not exceed the amount paid to TN for the product directly related to the alleged damage. However, in no event shall TN have any liability to a customer or any third party for products manufactures according to the customer's specifications.

### C. Return Procedure

The customer must follow this procedure for the return of defective items:

1. Locate the serial number(s) of the item(s) to be returned.
2. Determine the date the item(s) was received.
3. Contact Transition Networks Technical Support to determine if the problem can be corrected on site.

#### If not, and the product is covered by warranty, then:

- Call the distributor directly or contact TN.
- Request a Return Material Authorization (RMA).
- Ship the item, prepaid in original packaging to Transition Networks at the above address.
- Include the RMA number on the outside of the carton and/or on the Packing List.
- Include a copy of the RMA form.
- Include a copy of the original invoice or packing list (if possible) to expedite processing.
- The item(s) may be shipped by the customer or the distributor.
- Transition Networks will repair or replace the unit, at TN's discretion, and cover the cost of the return freight to the distributor or to the customer, whichever requested the RMA number.

If the item(s) was received **more than five years ago**, or if the item(s) is **no longer covered by warranty** for other reasons, then:

- Call the distributor or contact TN.
- Request a Material Repair Authorization number (MRA).
- Ship the item(s), prepaid, in the original packaging to Transition Networks at the above address.
- Include the MRA number on the outside of the carton add/or on the Packing List.
- Include a copy of the MRA form.
- Include a copy of the original invoice or packing list (if possible) to expedite processing.
- Only the customer (end-user) may send the items(s) to TN.
- TN will contact the customer after the item(s) have been received, inspected, and a cost estimate of the repair determined.
- The repair charges may be billed, with customer's approval, though the distributor, or on a prepaid or C.O.D. basis directly to the customer. The charges will include the cost of shipping.

The return authorization numbers are valid only for 90 days from the date issued.

## Warranty Statement

### A. Five Year Warranty

Transition Networks, Inc. (TN) warrants, for a period of five years, that TN products (with the exception of power supplies and fans that TN warrants for two years) will be free from defects in materials and workmanship, and will be in conformity with TN's specifications.

TN's warranty on products manufactured by or assembled for TN in accordance with a customer's specifications, is a five-year warranty that the goods conform to such specifications.

The warranty is invalidated if the goods have been subject to alterations, misuse, accident, Acts of God (e.g., damage by floods, lightning strikes, Etc.), tampering, improper maintenance, improper installation, or abuse. If the user is unsure about the proper means of installing or using the equipment, contact TN's free Technical Support or Network Design Services, which can be reached by:

**Telephone** 1.800.LAN.WANS or 612.941.7600  
**Fax** 612.941.2322  
**E-mail** techsupport@transition.com  
**Internet** http://www.transition.com

THE ABOVE WARRANTY IS EXCLUSIVE AND EXTENDS ONLY TO PRODUCTS ASSEMBLED BY TRANSITION NETWORKS, INC. TO THE EXTENT PERMITTED BY LAW, TN DOES NOT MAKE AND DISCLAIMS ALL OTHER WARRANTIES, EXCEPT TITLE, EXPRESSED OR IMPLIED, INCLUDING, BUT NOT LIMITED TO, ANY WARRANTY OF DESCRIPTION, MERCHANTABILITY, FITNESS FOR A PARTICULAR PURPOSE OR NON-INFRINGEMENT, AND ANY WARRANTY BASED UPON PRIOR WRITTEN OR ORAL REPRESENTATIONS REGARDING SUCH PRODUCTS MADE BY TN, ITS EMPLOYEES, AGENTS, OR REPRESENTATIVES.

### B. Limitations and Exclusions

If the customer believes any goods sold by TN are defective and within the warranty period, the following general procedure will be followed:

1. Locate the serial number and delivery date of the item(s).
2. Notify TN within the warranty period.
3. TN will promptly issue a return authorization form for the goods.
4. Upon receiving the form, the customer will promptly return the item(s) at customers own expense, shipped prepaid, to the distributor from which it was purchased, or directly to TN.

TN will only accept goods for return if the following conditions have been met:

1. A return form is obtained from TN.
2. The freight charges have been prepaid by the customer.
3. Goods are re-packed in their original packaging.

If under warranty TN shall, at its option, (1) repair the goods free of charge (2) replace the goods free of charge, or (3) accept the return of the item(s) and credit the current price to the reseller (within 90 days of purchase), or (4) if the goods are not under warranty, will repair the item(s) at a minimum charge of USD \$200 (two hundred U.S. dollars) per item.

THIS IS THE EXCLUSIVE REMEDY FOR ANY BREACH OF WARRANTY. IN NO EVENT SHALL TRANSITION NETWORKS BE LIABLE FOR SPECIAL, INDIRECT, INCIDENTAL OR CONSEQUENTIAL DAMAGES OF ANY KIND, WHETHER FOR BREACH OF ANY CONDITION OF SALE, FOR NEGLIGENCE, ON THE BASIS OF STRICT LIABILITY, CONTRACT, OR OTHERWISE AND IRRESPECTIVE OF WHETHER TN IS INFORMED BY CUSTOMER OF THE POSSIBILITY OF SUCH DAMAGES IN ADVANCE OF THIS SALE.

## Table of Contents

<b>1</b>	<b>INTRODUCTION</b>	<b>1</b>
	The 0403 Ethernet Pocket Hub	1
	0403 Pocket Hub Features	1
	Networking the 0403 Pocket Hub	2
	0403 Ethernet Pocket Hub Connectors	3
	RJ-45 Connectors	3
	Power Supply Adapter Connector	3
	Status LED	3
<b>2</b>	<b>SITE CONSIDERATIONS</b>	<b>4</b>
	Ensuring Compliance with Ethernet 802.3	5
	Segment Number	5
	Ensuring Correct 10BaseT Configuration	6
	Straight Through/Crossover Cable Orientation	6
	Straight Through/Crossover Pin Specifications	6
<b>3</b>	<b>INSTALLATION</b>	<b>7</b>
	Unpacking 0403 Pocket Hub	7
	Connecting 10Base2 Cable	8
	Connecting 10BaseT Cable	9
	Connecting Power to 0403 Pocket Hub	10
<b>4</b>	<b>OPERATION</b>	<b>11</b>
	Monitoring Power LED	11
	Monitoring Link/Transmit LEDs	11
<b>5</b>	<b>MAINTENANCE</b>	<b>12</b>
	Fault Isolation	12
	Technical Support Contact	12
	<b>0403 ETHERNET POCKET HUB SPECIFICATIONS</b>	<b>13</b>
	<b>CABLE SPECIFICATIONS</b>	<b>14</b>
	<b>WARRANTY STATEMENT</b>	<b>15</b>

# 1. INTRODUCTION

This guide is intended for the system or network administrator responsible for installing and monitoring a TRANSITION Networks 0403 Ethernet Pocket Hub. A working knowledge of local area network (LAN) operations, including familiarity with communications protocols used on interconnected LANs, is assumed.

## The 0403 Ethernet Pocket Hub

The Model 0403 10BaseT 4-Port Ethernet Hub (E-TBT-HB-0403), is a low cost Ethernet repeater. Designed to meet IEEE 802.3 10BaseT standards, the 0403 Pocket Hub is a fully functional repeater in a compact (4.80" X 2.77" X 0.95") case.

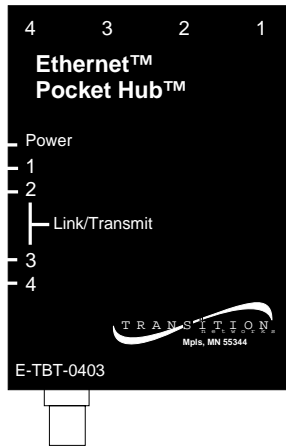

### 0403 Ethernet Pocket Hub Features

- automatic link partitioning (jabber function isolates network failures)
- preamble regeneration
- automatic polarity detection and correction

# Cable Specifications

## Cable Characteristics

The physical characteristics of the 10BaseT cable must meet or exceed IEEE 802.3 10BaseT specifications.

### 10BaseT Cable Specifications

Either shielded or unshielded twisted pair can be used. Level 3 wire or better is recommended.

- Gauge. . . . . 26 to 22 AWG
- Attenuation . . . . . Less than 11.5 dB @ 5-10 MHz
- Differential Characteristic . . . 85 -110  $\Omega$  Impedance @ 10 MHz
- Maximum Distance . . . . . 100 Meters (330 Feet)

## Segment Distance

Media Segment Type	Maximum Number MAU/Segment	Maximum Segment Length (meters)	Minimum Medium Propagation Velocity <sup>†</sup>	Maximum Medium End to End Propagation Delay/Segment
10Base2	30	185	0.65 c	950
10BaseT	2	100 <sup>†††</sup>	0.59 c	1000

<sup>†</sup> c =  $3 \times 10^8$  meters/second

<sup>†††</sup> Maximum segment length depends on the cable characteristics

# Model 0403 Ethernet Pocket Hub Specifications

## Dimensions

4.80" X 2.77" X 0.95" (122mm x 70mm x 24mm)

## Environment

Temperature: 0-50°C,  
Humidity 10-90%, non condensing,  
Altitude 0-10,000 feet.

## Power Supply Adapter

### AC Input:

PN	Requirement	Location
3518	120 volts, 60 hertz, 28 watts	USA/Canada/Mexico
3516	230 volts, 50 hertz, 28 watts	Europe
3514	100 volts, 50-60 hertz, 28 watts	Japan
3517	240 volts, 50 hertz, 28 watts	United Kingdom
3515	240 volts, 50 hertz, 28 watts	Australia

### DC Output:

9 volts at 500 mA maximum.

## Networking the 0403 Ethernet Pocket Hub

The 0403 Pocket Hub can function as the network backbone in both simple and complex networks.

When centrally located in a small installation, the 0403 Pocket Hub alone provides a simple, economical network solution.

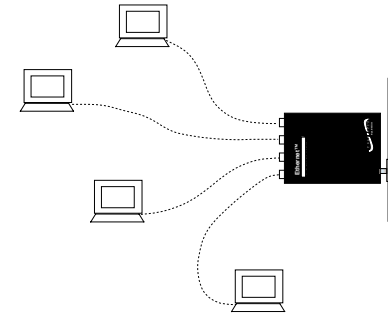

When linked to other 0403 Pocket Hubs or to other 802.3 compliant Ethernet repeaters, the Pocket Hubs function in complex Ethernet networks.

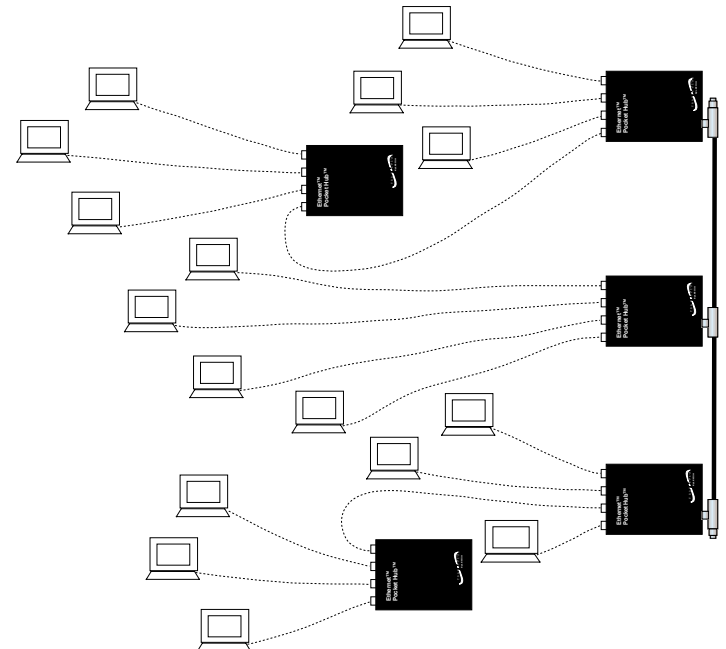

## 0403 Ethernet Pocket Hub Connectors and Status LEDs

### RJ-45 Connectors

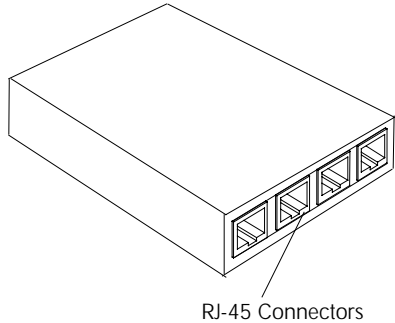

Four (4) 10BaseT RJ-45 jack connectors are located at one end of the 0403 Pocket Hub. The RJ-45 jacks support connection to shielded or unshielded 100 ohm twisted pair 10BaseT cable.

### BNC and Power Supply Adapter Connectors

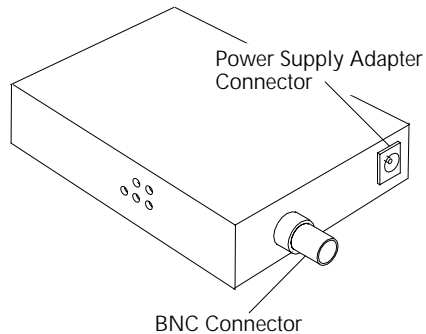

An external power supply adapter connector and a BNC connector are located at the other end of the 0403 Pocket Hub. The power supply adapter connector supplies external power. The BNC connector supports one connection to 10Base2 (thinnet) cable.

### Status LEDs

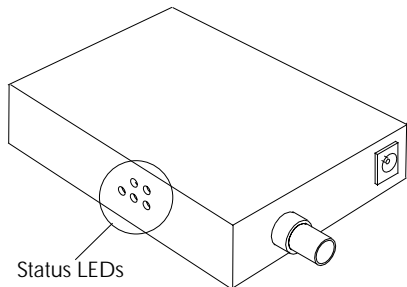

Power and Link/Transmit status LEDs are located at the side of the 0403 Pocket Hub. The **Power** LED indicates connection to power. The **Link/ Transmit** LEDs track the four 0403 Pocket Hub connections to 10BaseT.

## 5. MAINTENANCE

**WARNING: DO NOT, UNDER ANY CIRCUMSTANCES, open and attempt to repair the 0403 Pocket Hub or power supply adapter unit. Failure to observe this warning could result in personal injury or death from electrical shock.**

NOTE: Failure to observe the above warning will immediately void the warranty.

### Fault Isolation

If two network devices fail to communicate through the 0403 Pocket Hub, consider the following:

- Are the LEDs described in the previous section functioning properly?
- Do network devices have Link Integrity enabled?
- Do network devices communicate when the 0403 Pocket Hub is not installed between them?
- Is flat or "silver satin" wire used in site internal wiring?
- Are internal wiring patch cords, punch down blocks, and wall jacks properly pinned or configured?
- Is the thinnet cable unbroken and properly connected?
- Are network interface cards properly configured?

### Technical Support Contact

For assistance in fault isolation and in maintaining the 0403 Pocket Hub, contact:

**TN Technical Support (800) 260-1312**

or your local distributor.

---

## 4. OPERATION

The 0403 Pocket Hub normally requires no intervention beyond occasionally monitoring the Power and Link/Transmit LEDs.

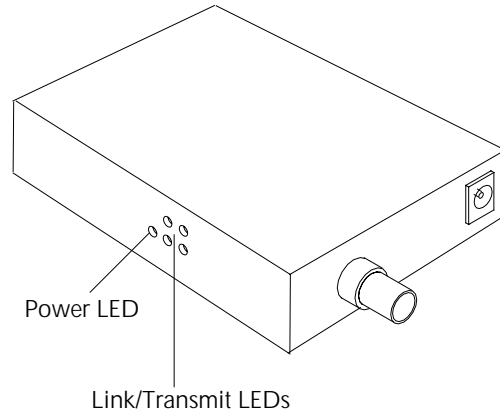

### Monitoring Power LED

The green **Power** LED is illuminated when the Pocket Hub is connected to power.

### Monitoring Link/Transmit LEDs

Each of the green **Link/Transmit** LEDs, associated with one of the eight RJ-45 ports:

- is illuminated when a device is connected to the RJ-45 port
- flashes slowly as data is transmitted
- flashes quickly if the associated RJ-45 port has been automatically partitioned.

---

## 2. SITE CONSIDERATIONS

The site for the 0403 Ethernet Repeater Hub must provide:

- AC power outlet for each Hub
- Adequate ventilation
- Standard environmental conditions
- Isolation from electrical noise, including radio transmitters and broadband amplifiers, motors, high power electrical lines, or fluorescent light fixtures

Additionally:

- The twisted pair cables should not run in the same conduit with power line cables.
- Phone lines should be separated from data cables.
- Flat or "silver satin" wires should not be used.

And:

- Since the 0400A Ethernet Pocket Hub functions as an Ethernet Repeater, the entire 0400A Ethernet Repeater Hub installation should comply with the IEEE Ethernet 802.3 specification, including segment number.
- RJ-45 connected cables should be configured as crossover or straight through according to installation requirements.

## Ensuring Compliance with Ethernet 802.3

Ethernet 802.3 specifications define segment number, as well as cable characteristics. (A segment is the cable connection between cable interfaces in an Ethernet LAN. Up to thirty 10Base2 connections can be made in one segment.)

When connecting Pocket Hubs, the transmission path between any two Data Terminating Equipment (DTE) terminals can consist of no more than five segments.

To assign segment numbers to cable connections:

1. Determine the two terminals in the network which are separated by the greatest number of segments.
2. Assign a segment path between the terminals by labeling the cable connected to one of the terminals "segment 1" and the segment connected to the other terminal "segment n" (n = total number of segments  $\leq$  5).
3. To verify that no segment paths contain more than n segments, assign segment paths and numbers to all other terminals.

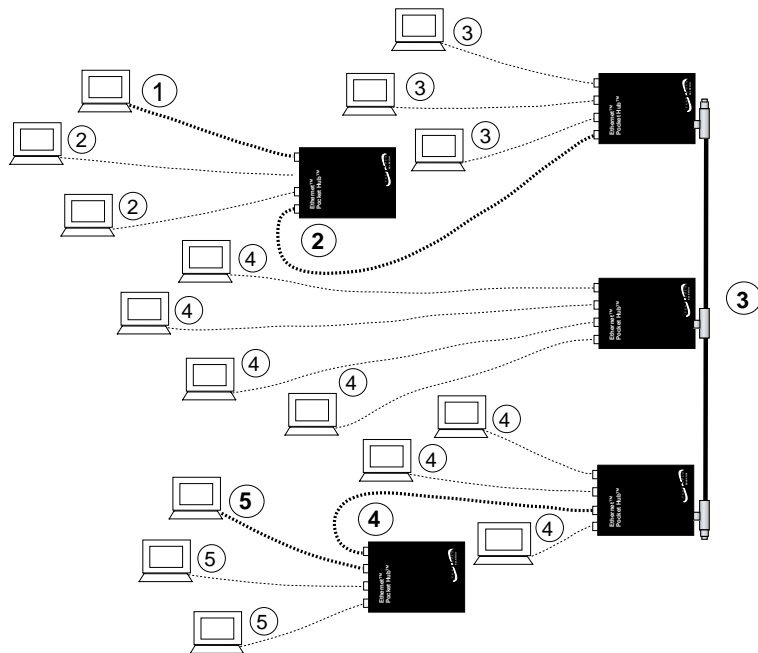

## Connecting Pocket Hub to Terminal Devices

Use a **straight through** cable to connect Pocket Hub to terminal devices.

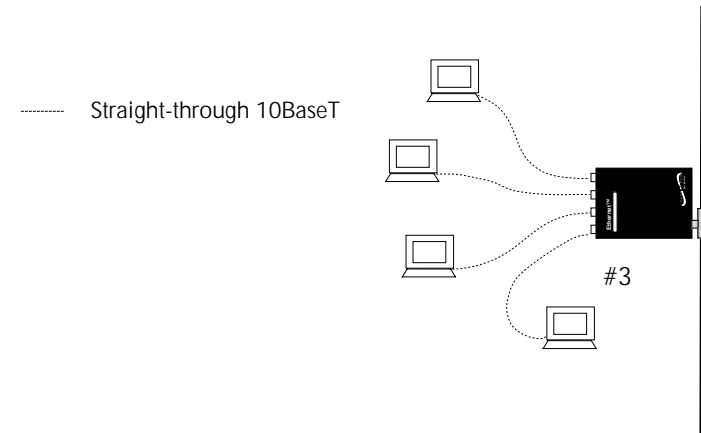

## Connecting Power to 0403 Pocket Hub

To power ON the 0403 Pocket Hub:

1. Locate the power receptacle on the back of the 0403 Pocket Hub.
2. Connect the 0403 Pocket Hub power connector end of the power supply adapter to the Pocket Hub.
3. Connect the external power connector end of the power supply adapter to external AC power.

NOTE: After the power supply adapter is connected to the 0403 Pocket Hub and to external power, the green **Power** LED is illuminated.

## Connecting 10BaseT Cable (continued)

### Connecting to External Hub through Wall Outlet

Use a **crossover** cable to connect Pocket Hub to the wall plate.  
 Use a **straight through** cable to connect Pocket Hub to terminal devices.

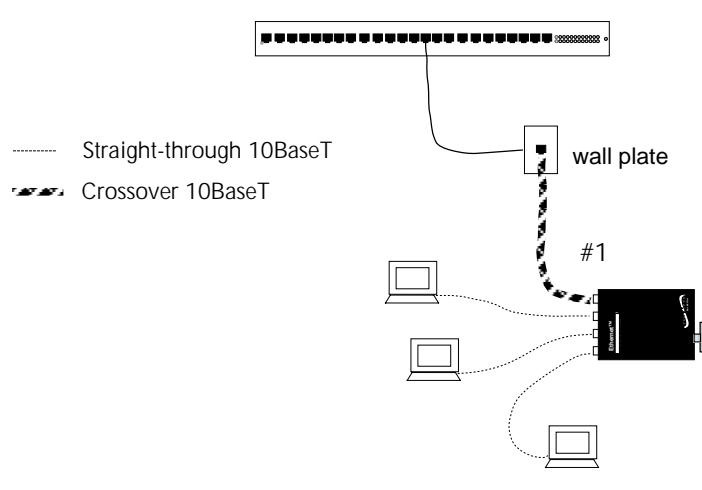

### Connecting two Pocket Hubs

Use a **crossover** cable to connect Pocket Hubs.  
 Use a **straight through** cable to connect Pocket Hub to terminal devices.(using straight through cable orientation) or to Pocket Hub RJ-45 jack connector (using crossover cable orientation).

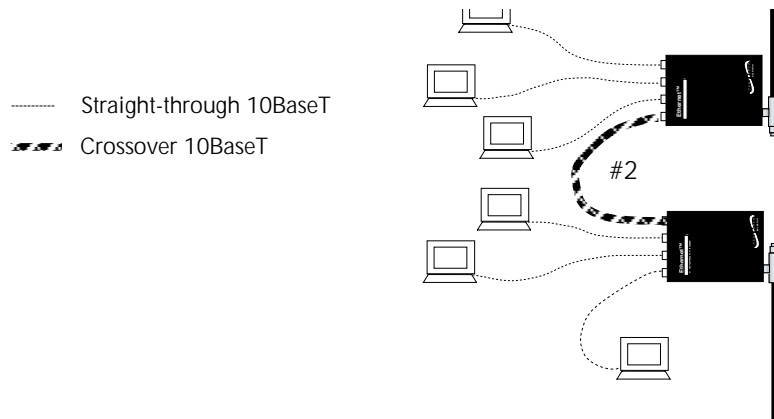

## Ensuring Correct 10BaseT Configuration

The 10BaseT cable and RJ-45 jacks for **Hub to Terminal** connections must be configured as **straight through**. The 10BaseT cable and RJ-45 jacks for **Hub to Hub** connections must be configured as **crossover**.

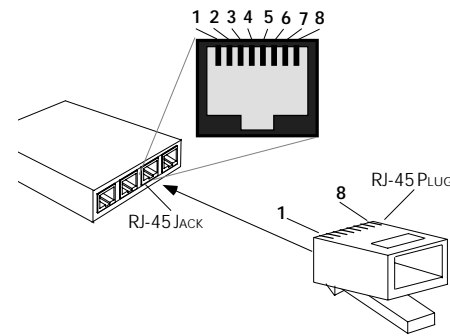

The two active pairs in a 10BaseT network are pins 1 & 2 and pins 3 & 6. Use only dedicated wire pairs (such as blue/white & white/blue, orange/white & white/orange) for the active pins.

### Straight Through Cable at RJ-45 Plug

<b>Hub</b> .....	<b>.PC, transceiver, NIC, printer</b>
RJ-45 Male .....	RJ-45 Male
1 .....	1
2 .....	2
3 .....	3
6 .....	6

### Crossover Cable at RJ-45 Plug

<b>Hub</b> .....	<b>.Hub</b>
RJ-45 Male .....	RJ-45 Male
1 .....	3
2 .....	6
3 .....	1
6 .....	2

### 3. INSTALLATION

NOTE: 0403 Ethernet Pocket Hub Link Integrity cannot be disabled. All devices connected to the Pocket Hub MUST have link functions enabled.

To install the 0403 Ethernet Pocket Hub:

- Unpack the 0403 Pocket Hub.
- Connect 10Base2 Cable to the 0403 Pocket Hub.
- Connect 10BaseT Cable to the 0403 Pocket Hub.
- Connect the 0403 Pocket Hub to power.

Direction is provided in the pages that follow.

#### Unpacking the 0403 Pocket Hub

The 0403 Ethernet Pocket Hub packing contents should include the following:

Item	Part Number
0403 Pocket Hub	E-TBT-HB-0403
Power Supply Adapter	3518, 3517, 3516, 3515, or 3514, (depending upon power configuration in country where installed)
User's Guide	7349

#### Connecting 10Base2 Cable

NOTE: 10Base2 cable MUST be properly terminated. Failure to terminate 10Base2 cable using 50 ohm terminators will cause data transfer to fail.

The 10Base2 segment MUST be grounded to "earth ground".

Up to thirty 10Base2 connections can be made in any one segment.

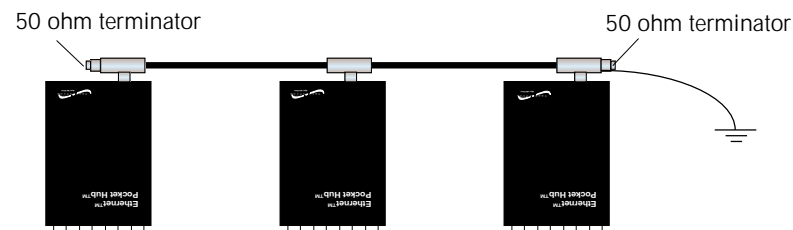

#### Connecting 10BaseT Cable

To connect 10BaseT Cable to Pocket Hub RJ-45 connectors:

1. Locate or build 10BaseT cables with the following characteristics:
  - 802.3 compliant (See page 14)
  - correct (straight through or crossover) cable configuration for site installation (See page 6)
  - male RJ-45 plug connectors installed at both cable ends.
2. Connect male RJ-45 plug connector at one end of 10BaseT cable to Pocket Hub RJ-45 jack connector.
3. Connect male RJ-45 plug connector at other end of 10BaseT cable to DTE terminal RJ-45 jack connector (using **straight through** cable orientation) or to Pocket Hub RJ-45 jack connector (using **crossover** cable orientation). NOTE: Examples are provided in the pages that follow.