

## Setting the Link Sense Switch:

The Link Sense switch can be turned ON to enable the Link integrity or it can be turned OFF to disable the Link integrity. The Link Sense switch is located and marked on the front of the media converter. (Refer to the picture on the front page of this user's guide). (A small regular screw driver is ideal for switching the Link Sense switch ON and OFF).

**Link Enable Position (ON):** When the Link switch is (ON) or enabled, it sends a Link pulse through the segment. This pulse is present only for current 10BaseT devices.

**Link Disable Position (OFF):** When the Link switch is (OFF) or disabled, the Link pulses are turned off. In this position the media converter can communicate with pre-10BaseT devices.

(Check your devices to see if they transmit Link pulses).

## Technical Support:

For more information about this product or other Transition Engineering products, call TE directly or your local Transition Engineering distributor.

Direct TE numbers are listed below:

TE Main Phone Numbers	(800) 325-2725 or (612) 941-7600
TE Technical Support Number	(800) 260-1312
TE Fax Number	(612) 941-2322
TE Bulletin Board	(612) 941-9304

## FCC Regulations:

Note: This equipment has been tested and found to comply with the limits for a Class A digital device, pursuant to Part 15 of the FCC Rules. These limits are designed to provide reasonable protection against harmful interference when the equipment is operated in a commercial environment. This equipment generates, uses, and can radiate radio frequency energy and, if not used in accordance with the instruction manual, may cause harmful interference to radio communications. Operation of this equipment in a residential area is likely to cause harmful interference in which case the user will be required to correct the interference at his own cost.

## Canadian Regulations:

Note: This digital apparatus does not exceed the Class A limits for radio noise for digital apparatus set out on the radio interference regulations of the Canadian Department of Communications.

## Trademarks:

Ethernet is a registered trademark of the Xerox Corporation, Inc.  
Transition Engineering is a trademark of Transition Engineering, Inc.

Rev 6/94  
P/N 7343.A

7090 Shady Oak Road  
Eden Prairie, MN 55344 USA

# 10Base2 to 10BaseT Media Converter User's Guide Model #: E-CX-TBT-03 Manual #: 7343.A 6/94

## About the Media Converter:

The Transition Engineering media converter, P/N E-CX-TBT-03 allows the network manager to interconnect existing Ethernet 10Base2 devices to a newly installed 10BaseT twisted pair type of network.

The media converter has a BNC female coax connection, an RJ-45 twisted pair connection and an external male coax barrel type jack for an external power supply. The media converter is ideal for installations that have thin coax cable already installed. It lets the network manager daisy chain up to 24 coax devices from the one 10BaseT twisted pair segment.

The media converter has two external switching functions. The first is for link enable/link disable, this allows the media converter to function with current 10BaseT standard equipment as well as older 10BaseT devices. The second switch is for termination of coax line, which is explained in detail in this installation guide.

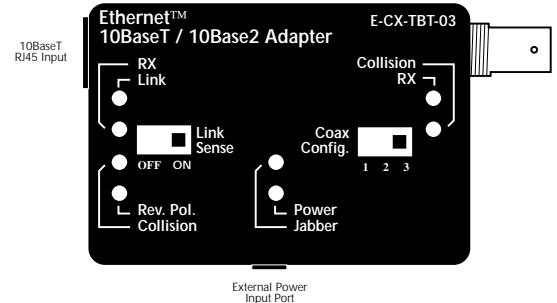

Case size dimensions: 3.75" x 2.38" x 0.88" (9.5cm X 6.0cm X 2.2cm)

## Media Converter Specifications:

- Media Converter Case Dimensions: 3.75" x 2.38" x 0.88" (9.5cm X 6.0cm X 2.2cm)
- Maximum Distance for 10BaseT Segment: 100 meters (330 feet), Level 3 or above twisted pair cable recommended
- Maximum Distance for Thin Coax Segment: 185 meters (610 feet), Approved Ethernet cable recommended
- Power Supply: External regulated 9VDC power supply.
- Environment: 0 – 50° C, 5% – 90% humidity non-condensing, 0 – 10,000 foot altitude
- Warranty: Two Years

## Monitoring the Media Converter's LEDs:

- |            |                |                                                                                                                                 |
|------------|----------------|---------------------------------------------------------------------------------------------------------------------------------|
| Main:      | Power-         | Lit green LED indicates normal operation                                                                                        |
|            | Jabber-        | Flashing red LED indicates Jabber is active                                                                                     |
| UTP Port:  | Receive (RX)-  | Flashing or lit green LED indicates packet(s) are being received                                                                |
|            | Link Status-   | Lit green LED indicates the unit is receiving Link pulses from a 10BaseT compliant device. (enable/disable via external switch) |
|            | Rev. Polarity- | Lit red LED indicates improper polarity on RX lines                                                                             |
|            | Collision-     | Flashing or lit red LED indicates a collision has occurred                                                                      |
| Coax Port: | Collision-     | Flashing or lit red LED indicates a collision has occurred                                                                      |
|            | Receive (RX)-  | Flashing or lit green LED indicates packet(s) are being received                                                                |

## Setting the Coax Config. Switch:

The first termination (switch position 1), 50 ohms, is used when connecting the end of a coax segment directly to the media converter's BNC port.

The second termination (switch position 2), NO termination, is used when connecting to the middle or in line of a thin coax segment. (For this position a BNC "T" must be connected to the media converter's BNC port).

The third termination (switch position 3), 25 ohms, is used when connecting directly to a workstation or DTE. (For this position a direct connection no longer than six inches must be used. A BNC M / M adapter is a preferred connection).

## Power Supply Requirements:

Replace power supply with only the equivalent input rating (refer to the table below) output rating (regulated 9VDC).

TE PN	Requirement	Location
3514	9VDC at 0.55A, 100VAC at 50–60Hz	Japan
3515	9VDC at 0.5A, 240VAC at 50Hz	Australia
3516	9VDC at 0.5A, 230VAC at 50Hz	Europe
3517	9VDC at 0.5A, 240VAC at 50Hz	United Kingdom
3518	9VDC at 0.55A, 120VAC at 60Hz	USA/Canada/Mexico

## RJ-45 Pin Specifications:

Individual wires that make up a **straight through** twisted pair modular cable are shown below. Each pair has designated pin connections on an RJ-45 modular connector. There are only two active pairs in a 10BaseT network, pins 1 & 2 and 3 & 6. Use only dedicated wire pairs (such as blue/white, white/blue, orange/white/white/orange, etc.).

Hub	to	Coax to TP Adapter
RJ-45 Male		RJ-45 Male
1 [RX +]	-----	[TX +] 1
2 [RX -]	-----	[TX -] 2
3 [TX +]	-----	[RX +] 3
6 [TX -]	-----	[RX -] 6

The following are the pins for a **crossover cable** to cascade from a 10BaseT Terminal to a Media Converter.

Coax to TP Adapter	to	Transceiver
RJ-45 Male		RJ-45 Male
1 [TX +]	-----	[RX +] 3
2 [TX -]	-----	[RX -] 6
3 [RX +]	-----	[TX +] 1
6 [RX -]	-----	[TX -] 2

