

# COMPLIANCE INFORMATION

UL Listed  
C-UL Listed (Canada)  
CISPR22/EN55022 Class A + EN55024  
CE Mark

## FCC Regulations

This equipment has been tested and found to comply with the limits for a class A digital device, pursuant to part 15 of the FCC rules. These limits are designed to provide reasonable protection against harmful interference when the equipment is operated in a commercial environment. This equipment generates, uses, and can radiate radio frequency energy and, if not installed and used in accordance with the instruction manual, may cause harmful interference to radio communications. Operation of this equipment in a residential area is likely to cause harmful interference, in which case the user will be required to correct the interference at the user's own expense.

## Canadian Regulations

This digital apparatus does not exceed the Class A limits for radio noise for digital apparatus set out on the radio interference regulations of the Canadian Department of Communications.

Le présent appareil numérique n'émet pas de bruits radioélectriques dépassant les limites applicables aux appareils numériques de la class A prescrites dans le Règlement sur le brouillage radioélectrique édicté par le ministère des Communications du Canada.

## European Regulations

### Warning

This is a Class A product. In a domestic environment this product may cause radio interference in which case the user may be required to take adequate measures.

### Achtung !

Dieses ist ein Gerät der Funkstörgrenzwertklasse A. In Wohnbereichen können bei Betrieb dieses Gerätes Rundfunkstörungen auftreten, in welchen Fällen der Benutzer für entsprechende Gegenmaßnahmen verantwortlich ist.

### Attention !

Ceci est un produit de Classe A. Dans un environnement domestique, ce produit risque de créer des interférences radioélectriques, il appartiendra alors à l'utilisateur de prendre les mesures spécifiques appropriées



**CAUTION: RJ connectors are NOT INTENDED FOR CONNECTION TO THE PUBLIC TELEPHONE NETWORK. Failure to observe this caution could result in damage to the public telephone network.**

Der Anschluss dieses Gerätes an ein öffentliches Telekommunikationsnetz in den EG-Mitgliedstaaten verstößt gegen die jeweiligen einzelstaatlichen Gesetze zur Anwendung der Richtlinie 91/263/EWG zur Angleichung der Rechtsvorschriften der Mitgliedstaaten über Telekommunikationsendeinrichtungen einschliesslich der gegenseitigen Anerkennung ihrer Konformität.

## Trademark Notice

All registered trademarks and trademarks are the property of their respective owners.

## Copyright Restrictions

© 2001, 2002 TRANSITION Networks.

All rights reserved. No part of this work may be reproduced or used in any form or by any means – graphic, electronic, or mechanical – without written permission from TRANSITION Networks.

Printed in the U.S.A.

33230.C



# 10BASE-T/100BASE-TX & 100BASE-FX

## 2-Port Bridging Media Converter

J/E-PSW-FX-01

# USER'S GUIDE

TRANSITION Networks J/E-PSW-FX-01 series two-port bridging media converters segment 10BASE-T copper Ethernet™ or 100BASE-TX copper Fast Ethernet™ collision domains from 100BASE-FX fiber Fast Ethernet™ collision domains.

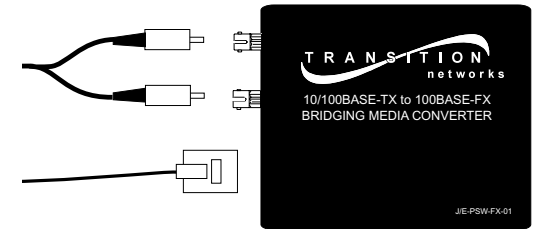

### J/E-PSW-FX-01(ST)

Provides an RJ-45 twisted-pair copper 10BASE-T/100BASE-TX connector and a set of RX (receive) and TX (transmit) ST 100BASE-FX connectors to **multimode 1300 nm** fiber-optic cable.

### J/E-PSW-FX-01(SC)

Provides an RJ-45 twisted-pair copper 10BASE-T/100BASE-TX connector and an RX (receive) and TX (transmit) SC 100BASE-FX connector to **multimode 1300 nm** fiber-optic cable.

### J/E-PSW-FX-01(SM)

Provides an RJ-45 twisted-pair copper 10BASE-T/100BASE-TX connector and an RX (receive) and TX (transmit) SC 100BASE-FX connector to **singlemode 1300 nm** fiber-optic cable.

J/E-PSW-FX-01 in the Network	2
Installation	4
Operation	7
Fault Isolation and Correction	8
Cable Specifications	9
Technical Specifications	11
Compliance Information	12

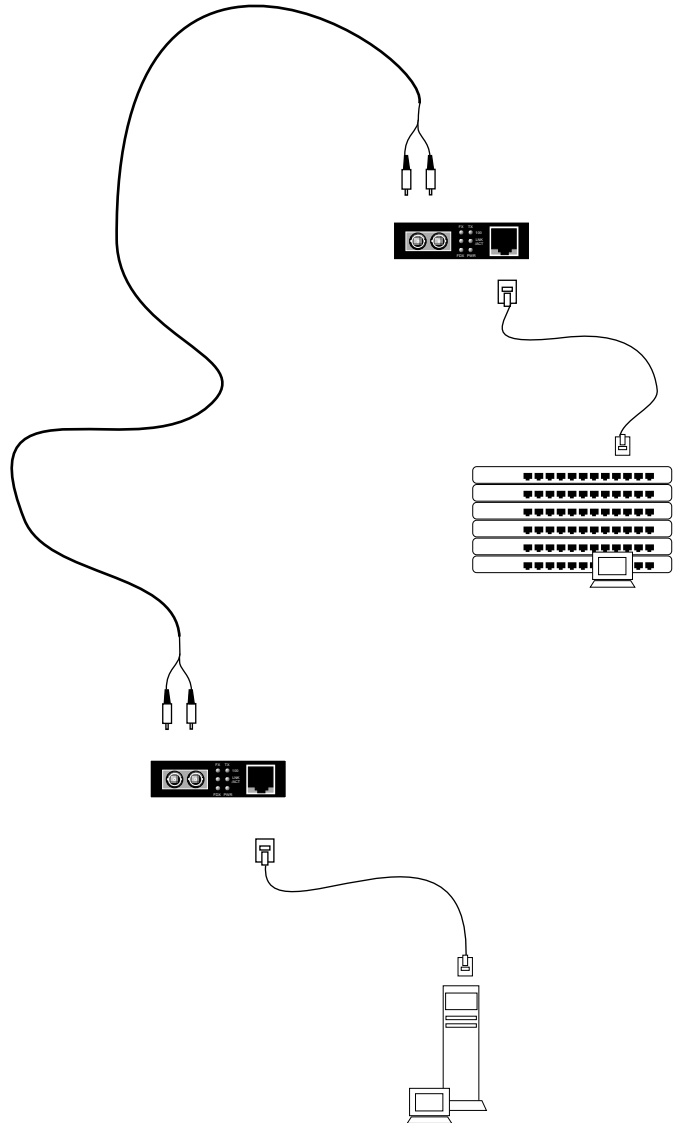

## THE J/E-PSW-FX-01 IN THE NETWORK

Use the J/E-PSW-FX-01 series 2-port bridging media converter singly or in pairs.



## TECHNICAL SPECIFICATIONS

<b>Standards</b>	IEEE 802.3, IEEE 802.3u
<b>Data Rate</b>	10 Mb/s, 100 Mb/s
<b>Dimensions</b>	26 mm x 71 mm x 97 mm (1 in x 2.8 in x 4 in)
<b>Filtering Rate</b>	Ethernet™, Fast Ethernet™ 14,880 pps
<b>Switching Method</b>	Store-and-Forward
<b>Power Requirement</b>	1.6 A @ +5V
<b>Power Consumption</b>	8 Watts
<b>Environment</b>	Typical Operating Temperature: 0° to 50°C (32° to 122°F) Storage Temperature: -20° to 85°C (-4° to 185°F) Humidity: 10-90%, non condensing Altitude: 0-10,000 feet
<b>Warranty</b>	Lifetime

 TRANSITION networks	<b>DECLARATION OF CONFORMITY</b>
<b>Name of Mfg:</b> Transition Networks 6475 City West Parkway, Minneapolis MN 55344 USA	
<b>Model:</b> J/E-PSW-FX-01 Series Media Converters	
<b>Part Number(s):</b> J/E-PSW-FX-01(ST), J/E-PSW-FX-01(SC), J/E-PSW-FX-01(SM)	
<b>Regulation:</b> EMC Directive 89/336/EEC	
Purpose: To declare that the <i>J/E-PSW-FX-01</i> to which this declaration refers is in conformity with the following standards. EN 55022:1994; EN 55024:1998; FCC Part 15 Class A; EN 60950 A4:1997; UL 1950	
<i>I, the undersigned, hereby declare that the equipment specified above conforms to the above Directive(s) and Standard(s).</i>	
 Stephen Anderson, Vice-President of Engineering	August 16, 2001 Date

# CABLE SPECIFICATIONS

## Fiber Cable

Bit error rate: ≤10<sup>-9</sup>

### MULTIMODE

Fiber Optic Cable Recommended: 62.5 / 125 μm multimode fiber  
Optional: 100 / 140 μm multimode fiber  
85 / 125 μm multimode fiber  
50 / 125 μm multimode fiber

#### J/E-PSW-FX-01(ST)

1300 nM  
Fiber-optic Transmitter Power: min: -19.0 dBm max: -14.0 dBm  
Fiber-optic Receiver Sensitivity: min: -30.0 dBm max: -14.0 dBm  
Fiber-optic Link Budget: 11.0 dB

**Typical** Maximum Cable Distance\*: 2 kilometers

#### J/E-PSW-FX-01(SC)

1300 nM  
Fiber-optic Transmitter Power: min: -19.0 dBm max: -14.0 dBm  
Fiber-optic Receiver Sensitivity: min: -30.0 dBm max: -14.0 dBm  
Fiber-optic Link Budget: 11.0 dB

**Typical** Cable Distance\*: 2 kilometers

### SINGLEMODE

Fiber-Optic Cable Recommended: 9 / 125 μm singlemode fiber  
Optional: 8.3 / 125 μm singlemode fiber  
8.7 / 125 μm singlemode fiber  
10 / 125 μm singlemode fiber

#### J/E-PSW-FX-01(SM)

1300 nM  
Fiber-optic Transmitter Power: min: -15.0 dBm max: -7.0 dBm  
Fiber-optic Receiver Sensitivity: min: -34.0 dBm max: -7.0 dBm  
Fiber-optic Link Budget: 19.0 dB

**Typical** Cable Distance\*: 20 kilometers

\*Actual distance dependent upon physical characteristics of network installation.

## Copper Cable

Category 5 shielded twisted-pair (STP) or unshielded twisted-pair (UTP) copper wire is required. DO NOT USE FLAT OR SILVER SATIN WIRE.

Gauge: 24 to 22 AWG  
Attenuation: 22.0 dB /100m @ 100 MHz  
Maximum Cable Distance: 100 meters

## MEDIA CONVERSION

The J/E-PSW-FX-01 series 2-port bridging media converter allows connection of 10BASE-T Ethernet™ or 100BASE-TX Fast Ethernet™ twisted-pair copper network devices to network devices on a 100BASE-FX Fast Ethernet™ fiber network.

## RATE CONVERSION

The J/E-PSW-FX-01 series 2-port bridging media converter allows connection of 10Mb/s terminal devices on a 10BASE-T legacy Ethernet™ copper network to 100Mb/s terminal devices on a 100BASE-FX Fast Ethernet™ fiber network.

## DISTANCE EXTENSION

In a half-duplex Ethernet™ or half-duplex Fast Ethernet™ environment, the J/E-PSW-FX-01 series 2-port bridging media converter extends network distances by segmenting CSMA/CD collision domains so that the 10BASE-T 5-Segment Rule or the 100BASE-TX /100BASE-FX 512-Bit Rule (see pages 6-7) applies separately to each CSMA/CD collision domain.

In a full-duplex Ethernet™ or full-duplex Fast Ethernet™ environment, the J/E-PSW-FX-01 series 2-port bridging media converter extends network distances to the physical cable limitations imposed by the selected twisted-pair copper cable and the selected fiber cable (see page 10).

## CONGESTION REDUCTION

The J/E-PSW-FX-01 series 2-port bridging media converter does not forward collision signals or error packets from one CSMA/CD collision domain to another, improving baseline network performance. And the bridging media converter filters packets destined for local devices, also reducing network congestion.

---

# INSTALLATION

## Connect Twisted-Pair Copper Cable to UTP/STP Connector (10BASE-T/100BASE-TX)

**CAUTION:** 10BASE-T/100BASE-TX connections between a hub and the media converter require crossover configuration cable. 10BASE-T/100BASE-TX cable connections between the media converter and a terminal, transceiver or NIC require straight-through configuration cable. (See page 7.) Failure to observe this caution will cause data transfer to fail.

### 10BASE-T AND THE ETHERNET COLLISION DOMAIN

- Refer to the 5-Segment Rule (page 6) before installing **half-duplex** 10BASE-T cable.
- Installing **full-duplex** twisted-pair cable avoids collision domain considerations; distances remain  $\leq 100$  meters.

### 100BASE-TX AND THE FAST ETHERNET COLLISION DOMAIN

- Refer to the 512-Bit Rule (page 7) before installing **half-duplex** 100BASE-TX cable.
- Installing **full-duplex** twisted-pair cable avoids collision domain considerations; distances remain  $\leq 100$  meters.
- NOTE: A Fast Ethernet collision domain can have only **ONE** CLASS I repeater OR **TWO** CLASS II repeaters.

### INSTALLING CABLE

To install 10BASE-T or 100BASE-TX cable:

1. Locate or build 10BASE-T or 100BASE-TX cables:
  - that are 803.2 compliant (page 10)
  - configured as *straight-through* or as *crossover*, according to site requirements (page 7)
  - with RJ-45 plug connectors installed at both cable ends.
2. Connect RJ-45 plug connector at one end of 10BASE-T or 100BASE-TX cable to bridging media converter RJ-45 jack connector.
3. Connect RJ-45 plug connector at other end of 10BASE-T or 100BASE-TX cable to RJ-45 jack connector on network device.

---

# FAULT ISOLATION AND RECOVERY

If a bridging media converter fails, ask the following questions:

1. Is the power LED on the media converter illuminated?

**NO**

- Is the power cord properly installed in the media converter and at the external power source?
- Does the external power source provide power?
- Contact Technical Support: (800) 260-1312

**YES**

- Proceed to step 2.

2. Is the Link LED illuminated on a port with twisted-pair installed?

**NO**

- Check UTP cables for proper connection/pin assignment.
- Contact Technical Support: (800) 260-1312

**YES**

- Proceed to step 3.

3. Is the Link LED illuminated on a port with fiber installed?

**NO**

- Check fiber cables for proper connection.
- Verify that TX and RX cables are connected to RX and TX ports, respectively, on 100BASE-FX device.
- Refer to Tech Tips available at: <http://www.transition.com>
- Contact Technical Support: (800) 260-1312

**YES**

- Contact Technical Support: (800) 260-1312

## OPERATION

### Using Status LEDs

Use the status LEDs on the media converter to monitor media converter and fiber network connections.

**100** Illuminated LED indicates fiber (FX) or copper (TX) 100 Mb/s operation.

**LINK ACT(ivity)** Steady LED indicates fiber (FX) or copper (TX) link connection; flashing LED indicates fiber (FX) or copper (TX) network activity.

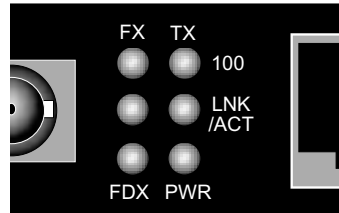

**FDX** Illuminated LED indicates full-duplex network connection; dark LED indicates half-duplex network connection.

**P(o)W(e)R** Steady LED indicates connection to external AC power.

## Connect Fiber Cable to TX/RX Connector (100BASE-FX)S

### 100BASE-FX AND THE FAST ETHERNET COLLISION DOMAIN

- Refer to the 512-Bit Rule (pages 8-9) before installing **half-duplex** 100BASE-FX cable.
- Use **full-duplex** fiber cable to avoid collision domain considerations and to extend network distances
- Note that a Fast Ethernet collision domain can have **ONLY ONE CLASS I** repeater **OR TWO CLASS II** repeaters.

### INSTALLING CABLE

To install 100BASE-FX cable:

1. Locate or build 100BASE-FX cables:
  - 100BASE-FX compliant (page 13)
  - with male transmit (TX) and receive (RX) fiber connectors installed at both cable ends.
2. Connect cable with connector installed at TX location on media converter to RX location on attached device.

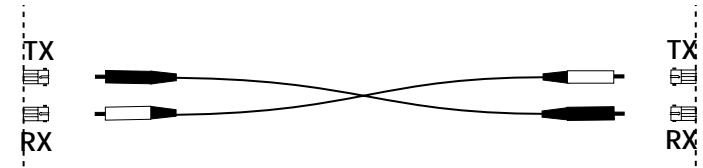

3. Connect cable with connector installed at RX location on media converter to TX location on attached device.

### Power the Bridging Media Converter

1. Install power adapter cord at back of media converter.
2. Connect power adapter plug to AC power.
3. Verify that media converter is powered by observing illuminated LED(s).

# Installing Network Cable

Use care when installing network cable to ensure that the restrictions that apply separately to each cable type, 10BASE-T, 100BASE-TX, and 100BASE-FX, and to each collision domain, are satisfied.

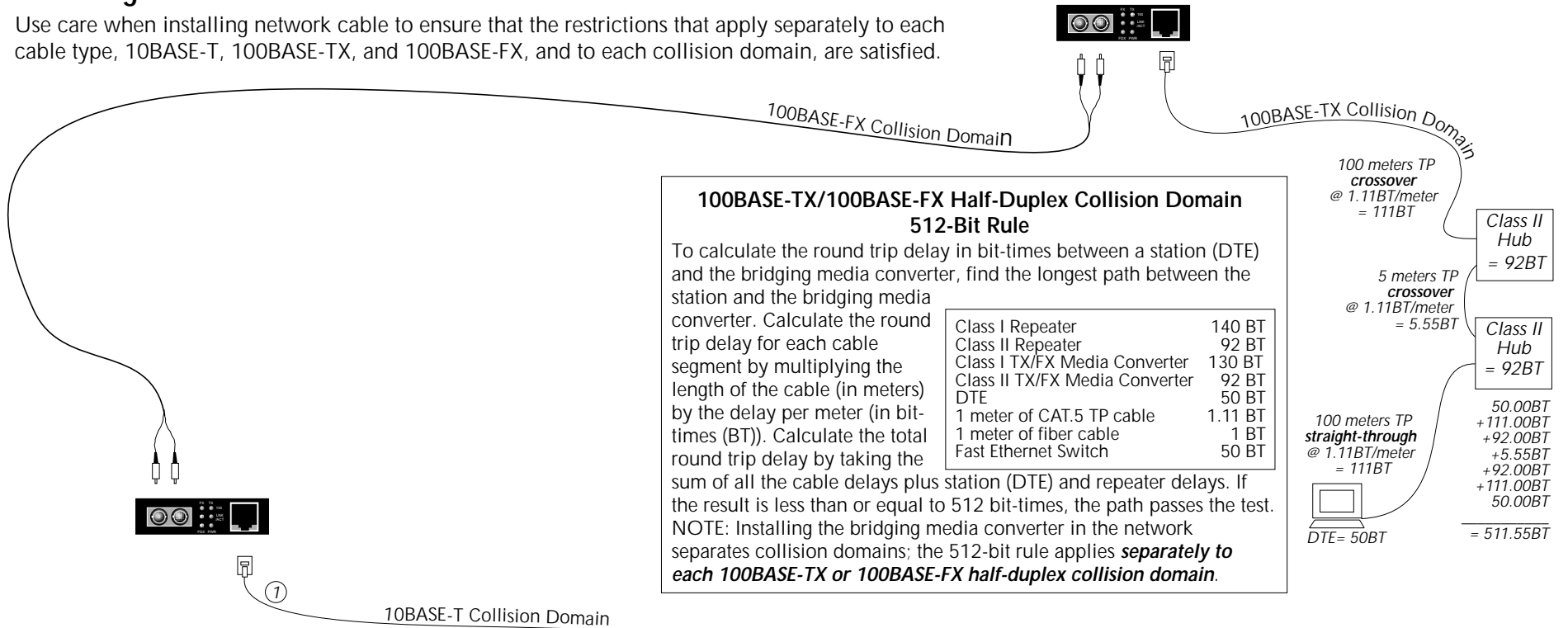

### 10BASE-T Half-Duplex Collision Domain

#### 5-Segment Rule

A segment is the cable connection between interfaces. A transmission path between any two terminal devices (including the Transition Networks' bridging media converter) in the same collision domain can consist of no more than five segments. Assign segment numbers to cable connections to determine the network device separated from the bridging media converter by the greatest number of segments. Define a segment path between that network device and the bridging media converter by labeling the cable connection to the bridging media converter "segment 1" and numbering each segment in the path to the network device up to "segment n" (n = total number of segments + 5). Verify that no segment path in the collision domain contains more than 5 segments. NOTE: Installing the bridging media converter in the network separates collision domains; the 10BASE-T 5-Segment Rule applies **separately to each 10BASE-T collision domain.**

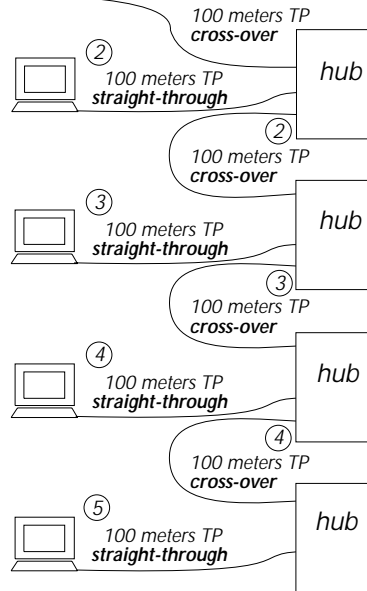

### Twisted-pair Copper Straight-Through /Crossover Configurations

The two active pairs in a 10BASE-T or 100BASE-TX network are pins 1 & 2 and pins 3 & 6. Use only dedicated wire pairs (such as blue/white & white/blue, orange/white & white/orange) for the active pairs.

The two wires in each pair of the cable must be twisted together for the entire length of the segment and kept twisted to within approximately 1/2 inch of any connector to ensure the integrity of the signal-carrying characteristics of the unshielded wire pair.

Crossover Cable at RJ-45 Plug		Straight-Through Cable at RJ-45 Plug	
Bridging Media Converter	Network Device	Bridging Media Converter	Network Device
RJ-45 Male	RJ-45 Male	RJ-45 Male	RJ-45 Male
1 (TX+)	3	1 (TX+)	1
2 (TX-)	6	2 (TX-)	2
3 (RX+)	1	3 (RX+)	3
6 (RX-)	2	6 (RX-)	6

NOTE: Media converter is pinned as DTE device.