

COMPLIANCE INFORMATION

UL Listed
C-UL Listed (Canada)
CISPR/EN55022 Class A

FCC Regulations

This equipment has been tested and found to comply with the limits for a class A digital device, pursuant to part 15 of the FCC rules. These limits are designed to provide reasonable protection against harmful interference when the equipment is operated in a commercial environment. This equipment generates, uses, and can radiate radio frequency energy and, if not installed and used in accordance with the instruction manual, may cause harmful interference to radio communications. Operation of this equipment in a residential area is likely to cause harmful interference, in which case the user will be required to correct the interference at the user's own expense.

Canadian Regulations

This digital apparatus does not exceed the Class A limits for radio noise for digital apparatus set out on the radio interference regulations of the Canadian Department of Communications.

Le présent appareil numérique n'émet pas de bruits radioélectriques dépassant les limites applicables aux appareils numériques de la class A prescrites dans le Règlement sur le brouillage radioélectrique édicté par le ministère des Communications du Canada.

European Regulations

Warning

This is a Class A product. In a domestic environment this product may cause radio interference in which case the user may be required to take adequate measures.

Achtung !

Dieses ist ein Gerät der Funkstörgrenzwertklasse A. In Wohnbereichen können bei Betrieb dieses Gerätes Rundfunkstörungen auftreten, in welchen Fällen der Benutzer für entsprechende Gegenmaßnahmen verantwortlich ist.

Attention !

Ceci est un produit de Classe A. Dans un environnement domestique, ce produit risque de créer des interférences radioélectriques, il appartiendra alors à l'utilisateur de prendre les mesures spécifiques appropriées



CAUTION: RJ connectors are NOT INTENDED FOR CONNECTION TO THE PUBLIC TELEPHONE NETWORK. Failure to observe this caution could result in damage to the public telephone network.

Der Anschluss dieses Gerätes an ein öffentliches Telekommunikationsnetz in den EG-Mitgliedstaaten verstößt gegen die jeweiligen einzelstaatlichen Gesetze zur Anwendung der Richtlinie 91/263/EWG zur Angleichung der Rechtsvorschriften der Mitgliedstaaten über Telekommunikationsendeinrichtungen einschliesslich der gegenseitigen Anerkennung ihrer Konformität.

Trademark Notice

All registered trademarks and trademarks are the property of their respective owners.

Copyright Restrictions

© 1999 TRANSITION Networks.

All rights reserved. No part of this work may be reproduced or used in any form or by any means – graphic, electronic, or mechanical – without written permission from TRANSITION Networks.

Printed in the U.S.A.

33110.A



Minneapolis, MN 55344 USA

Redundant Fast Ethernet™ 100BASE-TX/100BASE-FX 1300 Nanometer Media Converters E-R-TX-FX-01, E-R-TX-FX-01(SC), E-R-TX-FX-01(SM) USER'S GUIDE

The TRANSITION Networks E-R-TX-FX-01 series redundant Fast Ethernet™ media converters connect 100BASE-TX unshielded twisted pair copper to 1300 nm 100BASE-FX multimode OR to 1300 nm 100BASE-FX singlemode fiber. In the event of a failure in the primary copper or fiber connection, a fully redundant secondary connection is made available to the failed copper or fiber connection. Also, the copper and fiber media converter interfaces operate independently, so that a failure on one interface will not force a failure on the other interface.

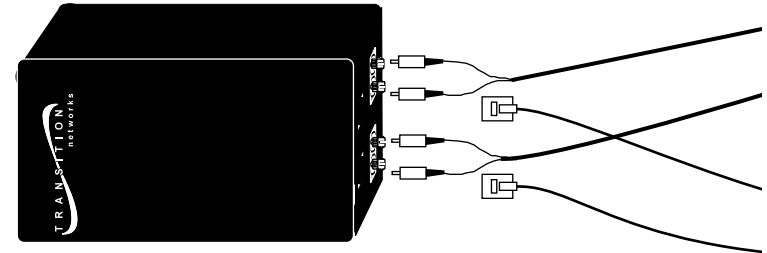

Switches at the side of the media converter allow selection of auto-negotiation and of full/half-duplex. Also, a port select timer (PST) switch* allows the network administrator to set different timer values (used when a primary connection is lost and a secondary connection is made) at each end of the copper/fiber interface.

E-R-TX-FX-01

Provides two (2) RJ-45 twisted pair 100BASE-TX connectors and two (2) sets of RX (receive) and TX (transmit) ST 100BASE-FX connectors to 1300 nm multimode fiber-optic cable.

E-R-TX-FX-01(SM)

Provides two (2) RJ-45 twisted pair 100BASE-TX connectors and two (2) sets of RX (receive) and TX (transmit) SC 100BASE-FX connectors to 1300 nm singlemode fiber-optic cable.

E-R-TX-FX-01(SC)

Provides two (2) RJ-45 twisted pair 100BASE-TX connectors and two (2) sets of RX (receive) and TX (transmit) SC 100BASE-FX connectors to 1300 nm multimode fiber-optic cable.

(*See note on page 5.)

E-R-TX-FX-01 in the Network 2
Installation 3
Operation 4
Fault Isolation and Correction 5
Cable Specifications 6
Technical Specifications 7
Compliance Information 8

E-R-TX-FX-01 IN THE NETWORK

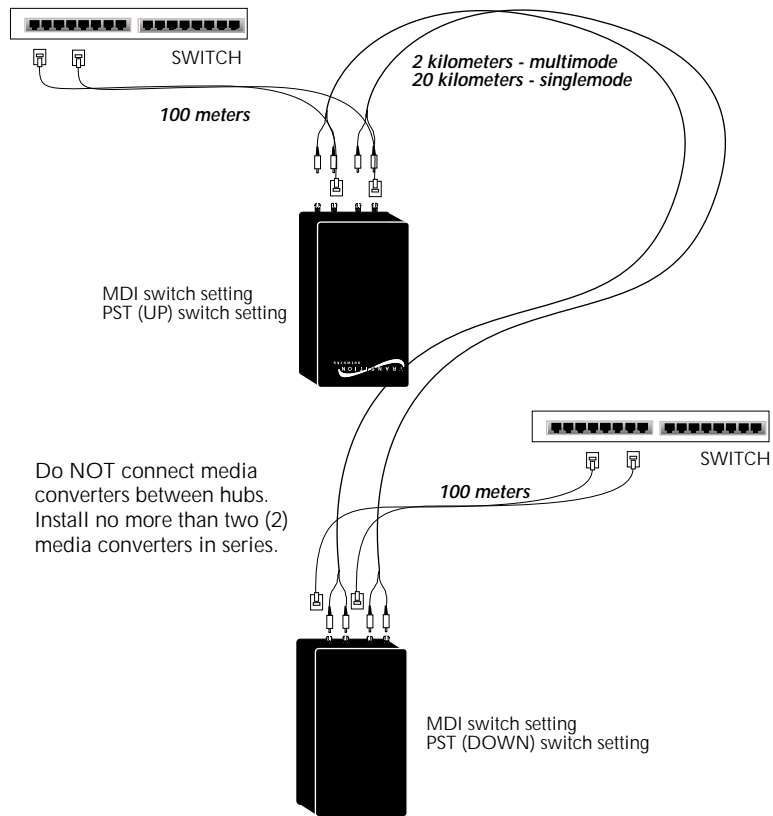

Recessed switches located on each side of the media converter are used to configure the media converter for the network. NOTE: Switch labels are located AT TOP of E-R-TX-FX-01 media converter.

MDI/MDI-X SWITCHES



(One for each RJ-45 port - located one on each side of media converter) Allows *straight-through* twisted-pair cable to be used for *crossover* 100BASE-TX connections.

4-POSITION SWITCH (3rd switch not used)



Auto-negotiation (UP) Detects and adapts to line speed and operating mode of attached device.

Full/Half-duplex (UP) Allows an attached full-duplex station to transmit and receive simultaneously. (DOWN) Allows an attached station to transmit and receive sequentially.

Port Select Timer (UP) Selects timer duration of eleven (11) seconds. (DOWN) Selects timer duration of five (5) seconds.

TECHNICAL SPECIFICATIONS

Standards	IEEE 802.3	
Case Dimensions	5.7" x 3.0" x 1.8"	(145mm x 76mm x 46mm)
Shipping Weight	3 pounds	(1.4 kilograms)
Delay	400nsec round trip	
Environment	Temperature:	0-50°C (32° to 122° F)
	Humidity	10-90%, non condensing
	Altitude	0-10,000 feet

Power Supply Requirements Replace power supply with only the equivalent input rating (see below) and output rating (unregulated 9-24VDC, 5.5W).

TN PN	Requirement	Location
3507	240 volts, 50 hertz	United Kingdom
3342	230 volts, 50 hertz	Europe
3340	120 volts, 60 hertz	USA/Canada/Mexico
3346	100 volts, 50-60 hertz	Japan
3511	240 volts, 50 hertz	Australia
3537	(with power cord: 3522)	South Africa

Warranty Lifetime

TRANSITION NETWORKS		DECLARATION OF CONFORMITY
Name of Mfg:	Transition Networks 6475 City West Parkway, Minneapolis MN 55344 USA	
Model:	Redundant Fast Ethernet™ Media Converters	
Part Number:	E-R-TX-FX-01	
Regulation:	EMC Directive 89/336/EEC	
Purpose:	To declare that the E-R-TX-FX-01 to which this declaration refers is in conformity with the following standards.	
	EMC-CISPR 22: 1985 Class A; EN 55022: 1988 Class A; EN 50082-1:1992; EN 60950 A4:1997; IEC 801.2, IEC 801.3, and IEC 801.4; IEC 950	
	<i>I, the undersigned, hereby declare that the equipment specified above conforms to the above Directive(s) and Standard(s).</i>	
		May 1, 1999
	Stephen Anderson, Vice-President of Engineering	Date

CABLE SPECIFICATIONS

The physical characteristics of the media cable must meet or exceed IEEE 802.3 specifications.

Fiber Cable

MULTIMODE

Fiber Optic Cable Recommended:	62.5 / 125 μ m multimode fiber	
Optional:	100 / 140 μ m multimode fiber	
	85 / 125 μ m multimode fiber	
	50 / 125 μ m multimode fiber	
Fiber Optic Transmitter Power:	min: -19.0 dBm	max: -14.0 dBm
Fiber Optic Receiver Sensitivity:	min: -32.5 dBm	max: -14.0 dBm
Wavelength :	850nm	
Bit error rate:	$\leq 10^{-9}$	
Maximum Cable Distance:	2 kilometers	

SINGLEMODE

Fiber Optic Cable Recommended:	9 μ m singlemode fiber	
Wavelength:	1300nm	
Bit error rate:	$\leq 10^{-9}$	
Fiber-optic Transmitter Power:	min: -15.0 dBm	max: -8.0 dBm
Fiber-optic Receiver Sensitivity:	min: -32.5 dBm	max: -8.0 dBm
Maximum Cable Distance:	20 kilometers	

Copper Cable

Category 5 twisted-pair copper wire is required. Either shielded twisted-pair (STP) or unshielded twisted-pair (UTP) can be used. **DO NOT USE FLAT OR SILVER SATIN WIRE.**

CATEGORY 5:

Gauge	24 to 22 AWG	
Attenuation	20 dB/1000' @ 10 MHz	
Differential Characteristic Impedance	100 Ω $\pm 10\%$ @ 10 MHz	
Maximum Cable Distance:	100 meters	

Straight Through Cable

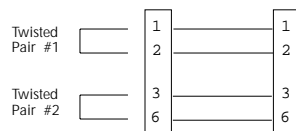

The two active pairs in a 100BASE-TX network are pins 1 & 2 and pins 3 & 6. Use only dedicated wire pairs (such as blue/white & white/blue, orange/white & white/orange) for the active pins.

INSTALLATION

Set Switches

NOTE: Switch labels are located AT TOP of E-R-TX-FX-01 media converter.

Use small flatblade screwdriver or similar device to set recessed switches according to site installation.

- Set EACH MDI/MDI-X switch to MDI for cable connection between switch and media converter OR to MDI-X for cable connection between media converter and terminal, transceiver or network interface card (NIC).
- Referring to drawing, set four-position switch according to network configuration.

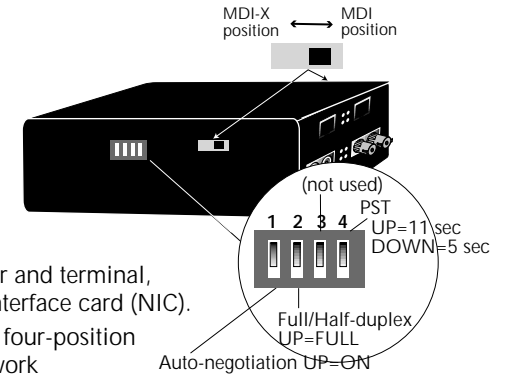

NOTE: If connecting two (2) media converters in series, set the PST (#4) switch on one media converter to the UP position AND set the PST (#4) switch on the other media converter to the DOWN position.

Install Cable

COPPER

NOTE: KEEP TWISTED PAIR RUNS AS SHORT AS POSSIBLE.

- Locate or build 802.3 compliant cables with straight through configuration and male RJ-45 plug connectors.
- Connect male RJ-45 plug connector at one end of cable to media converter RJ-45 jack connector.
- Connect male RJ-45 plug connector at other end of cable to DTE terminal RJ-45 jack connector (with MDI switch set to MDI-X) or to switch RJ-45 jack connector (with MDI switch set to MDI).

FIBER

- Locate or build 802.3 compliant fiber cable with male two-stranded TX to RX connectors *appropriate to the media converter* installed at both ends.
- Connect male **TX** and **RX** cable connectors at one end of cable to **TX** and **RX** female connectors, respectively, on media converter.
- Connect male **TX** and **RX** cable connectors at other end of cable to **RX** and **TX** connectors of 802.3 compliant fiber device.

Connect to Power

- Install Power Adapter cord at back of media converter.
- Connect Power Adapter 3-prong plug to AC power.
- Verify that media converter is powered by observing illuminated LED(s).

OPERATION

After installation, the media converter should function without operator intervention.

Status LEDs:

Use the status LEDs to monitor media converter operation in the network.

NOTE: Illuminated PRI(mary) and/or SEC(ondary) LEDs indicate media converter connection to external power.

PRI	Copper Primary Port - Steady green LED indicates primary copper port is being selected by internal control logic
SEC	Copper Secondary Port - Steady green LED indicates secondary copper port is being selected by internal control logic
RXC	Receive Copper Port - Steady green LED indicates valid data is being detected on copper interface
SDC	Signal Detect Copper - Steady green LED indicates Link established on copper port selected
PRI:	Fiber Primary Port - Steady green LED indicates primary fiber port is being selected by internal control logic
SEC	Fiber Secondary Port - Steady green LED indicates secondary fiber port is being selected by internal control logic
SDF	Signal Detect Fiber - Steady green LED indicates optical signal present on fiber port selected
RXF	Receive Fiber Port - Steady green LED indicates non-IDLE symbols are being detected on fiber interface

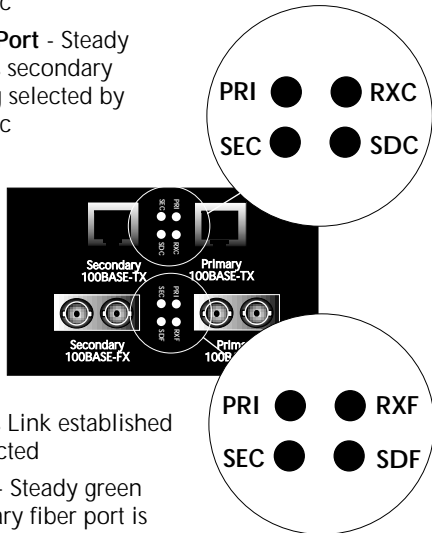

FAULT ISOLATION and CORRECTION

If the media converter fails, isolate and correct the failure by determining the answers to the following questions and then taking the indicated action:

1. Are the PRI(mary)/SEC(ondary) LEDs on the media converter illuminated or alternating between between primary and secondary ports?

NO

- Is the power adapter the proper type of voltage and cycle frequency for AC outlet?
NOTE: Refer to the "Power Supply Requirements" on page 7.
- Is the power adapter properly installed in the media converter and in the outlet?
- *Are PST switch settings on two media converters installed in series in the network set to different values?
- Contact Technical Support at (800) 260-1312/ (800) LAN-WANS.

YES

- Proceed to step 2.

2. Is the 100BASE-TX SDC (Signal Detect/Copper) LED illuminated?

NO

- Check UTP cables for proper connection.
- Verify MDI/MDI-X switch position.
- Contact Technical Support at (800) 260-1312/ (800) LAN-WANS.

YES

- Proceed to step 3.

3. Is the 100BASE-FX SDF (Signal Detect/Fiber) LED illuminated?

NO

- Check fiber cables for proper connection.
- Verify that TX and RX cables on media converter are connected to RX and TX ports, respectively, on the other 100BASE-FX device.
- Refer to Tech Tips available at: <http://www.transition.com>
- Contact Technical Support at (800) 260-1312/ (800) LAN-WANS.

YES

- Contact Technical Support at (800) 260-1312/ (800) LAN-WANS.

*NOTE: Setting PST switch settings on two media converters installed in series in the network to different values (11 seconds and 5 seconds) ensures, in the event of common power failure or similar incident, a sufficient delay in the time required to establish each link so that communication between the media converters is guaranteed.