

MEDIA CONVERTER TECHNICAL SPECIFICATIONS

Standards	IEEE 802.5, 802.5j	
Case dimensions	4.75" x 3.0" x 1.0" (119mm x 76mm x 25mm)	
Shipping Weight	2 pounds (0.9 kilograms)	
Delay	50nsec round trip	
Environment	Temperature:	0-40°C (32° to 104° F)
	Humidity	10-90%, non condensing
	Altitude	0-10,000 feet
Warranty	Five years	

Power Supply Requirements Replace power supply with only the equivalent input rating (see below) and output rating (regulated 9VDC at 550 mA).

<u>TN PN</u>	<u>Requirement</u>	<u>Location</u>
3517	240 volts, 50 hertz	United Kingdom
3516	230 volts, 50 hertz	Europe
3518	120 volts, 60 hertz	USA/Canada/Mexico
3514	100 volts, 50-60 hertz	Japan
3515	240 volts, 50 hertz	Australia



CAUTION: RJ connectors are NOT INTENDED FOR CONNECTION TO THE PUBLIC TELEPHONE NETWORK. Failure to observe this caution could result in damage to the public telephone network.

Der Anschluss dieses Gerätes an ein öffentliches Telekommunikationsnetz in den EG-Mitgliedstaaten verstößt gegen die jeweiligen einzelstaatlichen Gesetze zur Anwendung der Richtlinie 91/263/EWG zur Angleichung der Rechtsvorschriften der Mitgliedstaaten über Telekommunikationsendeinrichtungen einschliesslich der gegenseitigen Anerkennung ihrer Konformität.

Compliance Information

UL Listed
C-UL Listed (Canada)
CISPR/EN55022 Class A

FCC Regulations

This equipment has been tested and found to comply with the limits for a class A digital device, pursuant to part 15 of the FCC rules. These limits are designed to provide reasonable protection against harmful interference when the equipment is operated in a commercial environment. This equipment generates, uses, and can radiate radio frequency energy and, if not installed and used in accordance with the instruction manual, may cause harmful interference to radio communications. Operation of this equipment in a residential area is likely to cause harmful interference, in which case the user will be required to correct the interference at the user's own expense.

Canadian Regulations

This digital apparatus does not exceed the Class A limits for radio noise for digital apparatus set out on the radio interference regulations of the Canadian Department of Communications.

European Regulations

Warning

This is a Class A product. In a domestic environment this product may cause radio interference in which case the user may be required to take adequate measures.

Copyright Restrictions

© 1998 TRANSITION Networks.

All rights reserved. No part of this work may be reproduced or used in any form or by any means – graphic, electronic, or mechanical – without written permission from TRANSITION Networks.

Trademark Notice

All registered trademarks and trademarks are the property of their respective owners.

33086.B



Minneapolis, MN 55344 USA

Token Ring Copper/Fiber *Media Converters*

TR-CF-01, TR-CF-01(SM)

USER'S GUIDE

The TRANSITION Networks Token Ring copper-to-fiber media converters connect either unshielded or shielded Token Ring twisted-pair copper cable to *multimode* fiber-optic cable (TR-CF-01) OR to *singlemode* fiber-optic cable (TR-CF-01(SM)).

TR-CF-01

Provides a Token Ring RJ-45 twisted-pair connector and an RX (receive) and a TX (transmit) ST connector to *multimode* fiber-optic cable for fiber network extension distances up to 2 kilometers.

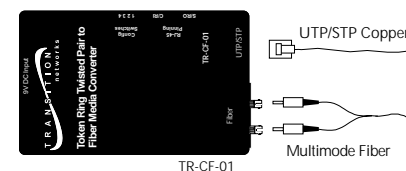

TR-CF-01(SM)

Provides a Token Ring RJ-45 twisted-pair connector and an RX (receive) and a TX (transmit) ST connector to *singlemode* fiber-optic cable for fiber network extension distances up to 15 kilometers.

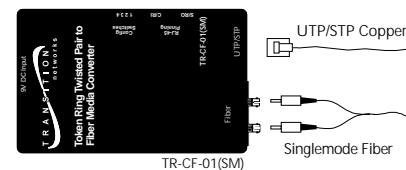

Both media converters function at 4Mb/s or 16Mb/s in half-duplex mode or, when connected to devices capable of full-duplex connectivity, in full-duplex mode for up to 32Mb/s total throughput.

Status LEDs:

P(o)w(e)r Steady green LED indicates connection to external AC power.

Ins(erted) Steady green LED indicates twisted-pair and fiber connections negotiated link.

S(ignal) D(etect) C(opper) Steady green LED indicates twisted-pair link is up and ready to insert.

S(ignal) D(etect) F(iber) Steady green LED indicates fiber link is up and ready to insert.

NOTE: The fiber interface LEDs are NOT illuminated until the twisted-pair side has been initialized and asserts a phantom voltage to the fiber. (See a description of the activity of the Token Ring twisted-pair to fiber signal in "Media Converters in the Network" on page 4.)

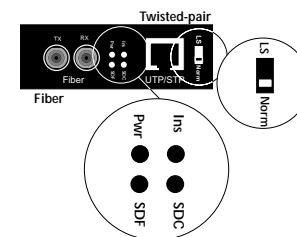

Switch:

Norm(al) Used for most network operation.

L(oop-back) S(witch) Used ONLY at the direction of Transition Networks Technical Support.

NOTE: For more information, go to www.transition.com/support, select **Tech Tips**, and then select the Token Ring media converter.

INSTALLATION NOTES

Twisted-pair Cable

- Category 5 twisted-pair cable is recommended; Category 3 and 4 are supported at reduced cable lengths.

Fiber Extension Cable

- Be certain that the fiber extension cable is correct for distances required at the site installation.

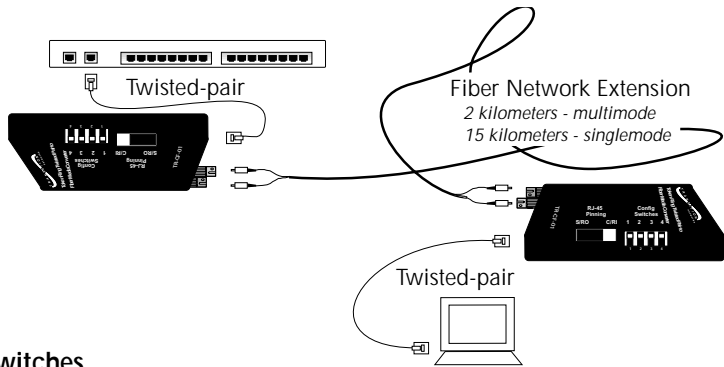

Switches

- Switches on the side of the media converter are used to configure each media converter according to its location in the Token Ring network. **SET THE SWITCHES ON THE MEDIA CONVERTER BEFORE CONNECTING TO POWER.**

Using the switch setting references on page 3 and pages 4-5:

- Be certain that the media converter **mode** is set correctly for the site installation
- Be certain that the media converter **active/passive** state is set correctly for the site installation
- Be certain that the media converter IEEE 802.5j **compliance/non-compliance** state is set correctly for the site installation
- Be certain that the twisted-pair cable **configuration** is set correctly (straight through/RO or crossover/RI) for the site installation.

Power Connections

- Install the media converter with the power supply provided. (Output 9 VDC regulated, 550 mA).
- Connect the power supply cable to the media converter BEFORE connecting the power supply cable to the AC outlet.
- Do NOT connect more than two media converters in series.

TOKEN RING CABLE SPECIFICATIONS

The physical characteristics of the media cable must meet or exceed IEEE 802.5 and 802.5j specifications.

Fiber Cable and Connector Specifications

Cable Characteristics:

MULTIMODE

Fiber Optic Cable Recommended:	62.5 / 125 μm multimode fiber	
Fiber Optic Transmitter Power:	min: -19.0 dBm	max: -14.0 dBm
Fiber Optic Receiver Sensitivity:	min: -32.5 dBm	max: -14.0 dBm
Wavelength:	850nm	
Bit error rate:	≤10 ⁻⁹	
Maximum Cable Distance:	2 kilometers	

SINGLEMODE

Fiber Optic Cable Recommended:	9 μm singlemode fiber	
Fiber Optic Transmitter Power:	min: -25.0 dBm	max: -22.0 dBm
Fiber Optic Receiver Sensitivity:	min: -32.5 dBm	max: -14.0 dBm
Wavelength:	1300nm	
Bit error rate:	≤10 ⁻⁹	
Maximum Cable Distance:	15 kilometers	

Connector Characteristics:

ST type connectors (SMA type available upon request)

Twisted Pair Cable and Connector Specifications

Cable Characteristics:

Category 3 wire or better is required; category 5 wire is recommended. Either shielded twisted pair (STP) or unshielded twisted pair (UTP) can be used. DO NOT USE FLAT OR SILVER SATIN WIRE.

Category 3:

Gauge	24 to 22 AWG
Attenuation	28 dB/1000' @ 10 MHz
Differential Characteristic Impedance	100 Ω ±10% @ 10 MHz

Category 5:

Gauge	24 to 22 AWG
Attenuation	20 dB/1000' @ 10 MHz
Differential Characteristic Impedance	100 Ω ±10% @ 10 MHz

Maximum Cable Distance:

50 meters (165 feet)

Connector Characteristics:

Twisted pair connection requires two active pairs configured as straight through. The two active pairs in a Token Ring network are pins 4 & 5 and pins 3 & 6. Use only dedicated wire pairs (such as blue/white & white/blue, orange/white & white/orange) for the active pins.

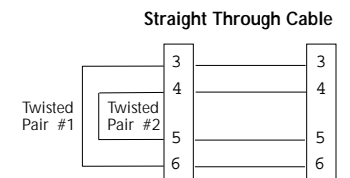

MEDIA CONVERTER TROUBLESHOOTING SUGGESTIONS











If a Media Converter fails, ask the following questions:

- Is the **p(o)w(e)r** LED on the media converter illuminated?
 - NO**
 - Is the power adapter the proper voltage and cycle frequency for the AC outlet? NOTE: Refer to the "Power Supply Requirements" on the back page.
 - Is the power adapter properly installed in the media converter and in the outlet?
 - Are the two sides of the network the same speed: 4Mb/s OR 16Mb/s?
 - Contact Technical Support: (800) 260-1312/(800) LAN-WANS.
 - YES**
 - Proceed to step 2.
- Is the **S(ignal) D(etect) C(opper)** LED illuminated?
 - NO**
 - Check twisted pair cables for proper connection.
 - Check RJ-45 Pinning Switch for correct twisted pair cable configuration.
 - Contact Technical Support: (800) 260-1312/(800) LAN-WANS.
 - YES**
 - Proceed to step 3.
- Is the **S(ignal) D(etect) F(iber)** LED illuminated?
 - NO**
 - Check fiber cables for proper connection.
 - Verify that TX and RX cables on media converter are connected to RX and TX ports, respectively, on other device.
 - Contact Technical Support: (800) 260-1312/(800) LAN-WANS.
 - YES**
 - Proceed to step 4.
- Is the **Ins(erted)** LED illuminated?
 - NO**
 - Restart the workstation to restart the initialization process.
 - Contact Technical Support: (800) 260-1312/(800) LAN-WANS.
 - YES**
 - Contact Technical Support: (800) 260-1312/(800) LAN-WANS.

SWITCH SETTINGS

Switch settings shown below are used when configuring straight-through/RO or crossover/RI cable configuration, network installation mode (1-4), active or passive state of attached concentrator, and network compliance or non-compliance with the IEEE 802.5j standard.



 <p>C(oncentrator) /R(ing) O(ut): Selected when installing media converter to active/passive concentrator RO port.</p>	 <p>Mode 1: Selected when installing media converter between station and fiber extension.</p>  <p>Mode 2: Selected when installing media converter between fiber extension and active concentrator RI or lobe port.</p>  <p>Mode 3: Selected when installing media converter between fiber extension and passive concentrator RI port.</p>  <p>Mode 4: Selected when installing media converter between passive/active concentrator RO port and fiber extension.</p>
 <p>S(tation) /R(ing) I(n): Selected when installing media converter to active/passive concentrator RI port.</p>	 <p>Active: Selected when installing media converter to active concentrator Ring port.</p>  <p>Passive: Selected when installing media converter to passive concentrator Ring port.</p>  <p>802.5j: Selected when installing media converter in 802.5j-compliant network.</p>  <p>Non-802.5j: Selected when installing media converter in non-802.5j-compliant network.</p>

MEDIA CONVERTERS in the NETWORK

The fiber standard to which the media converters comply is the approved IEEE 802.5j standard. However, using a switch setting, the media converter can be adapted to some of the proprietary implementations that evolved before the standard. This proprietary mode reduces the protocol frequency to 1-10kilohertz.

Token Ring topology combines the physical star with the logical ring. Any break in the Token Ring prevents transmission of the 'token' on which the Token Ring protocol is based and therefore prevents data transmission. Token Ring concentrators implement a loopback function which, in the event of a break in the ring, loops back the ring to isolate the break. Transition Networks Token Ring media converters are designed to preserve this fault-recovery feature.

Insertion into the Token Ring is always initiated when the station or concentrator Ring-Out port asserts a phantom voltage onto the twisted-pair line. The media converter detects this voltage and generates an 'insertion key' onto the fiber, then loops back the twisted-pair receive to transmit and the fiber receive to transmit. When an 'Insertion Key Echo' is received on the fiber, the media converter disables the loopback and passes the twisted-pair receive to fiber transmit and the fiber receive to the twisted-pair transmit. On the other side of the fiber, the converter drives phantom voltage and detect for a valid link and the fiber and twisted-pair interfaces are in a loopback state. Upon detecting a valid link, the fiber and twisted-pair interfaces disable the loopback. Thus, the Token Ring path is not opened until a full check from end to end is done, protecting the integrity of the Token Ring.

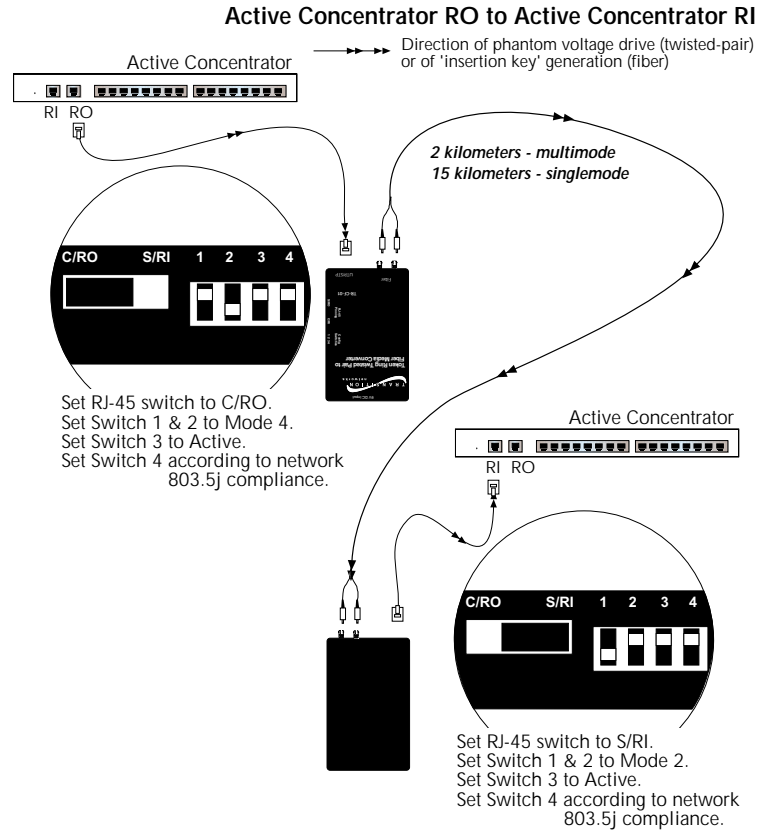
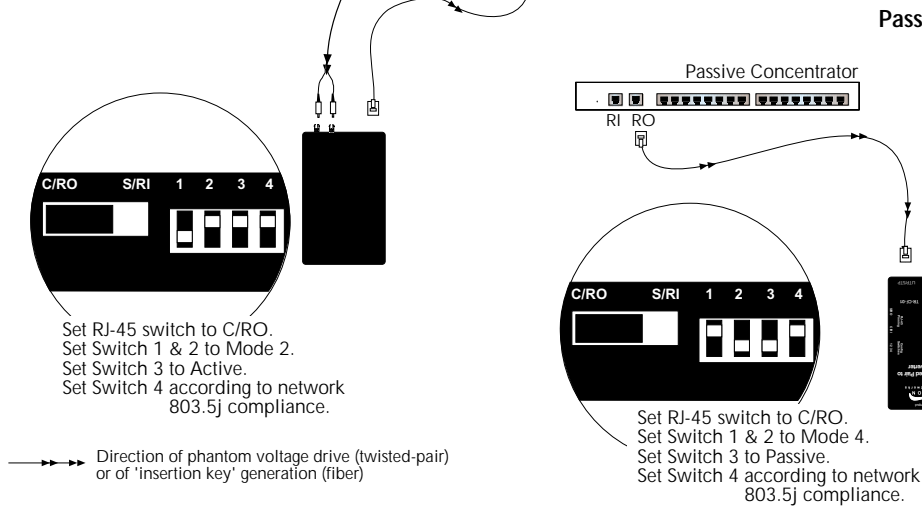
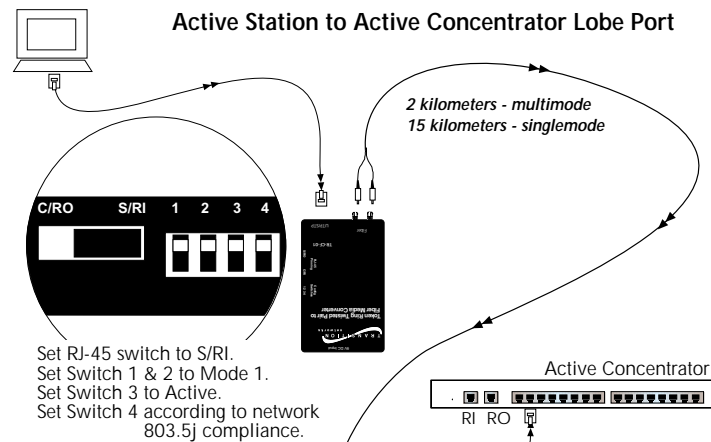

Direction of phantom voltage drive (twisted-pair) or of 'insertion key' generation (fiber)

Direction of phantom voltage drive (twisted-pair) or of 'insertion key' generation (fiber)