

User's Guide

J/VD-TX-01, J/VD-RX-01 and J/VD-MRX-01

Stand-Alone AM Video Copper-to-Fiber Video System

- AM Video
- NTSC, PAL, SECAM compatible
- Automatic gain control (AGC)
- Realtime full color video
- Plug-and-play design for easy installation
- CCTV video equipment compatible
- One-way signal transmission through the system
- Extended temperature rated for use in controlled outdoor applications

J/VD-TX-01

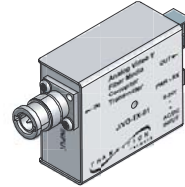

The J/VD-TX-01 fiber transmitter permits connecting a video camera to a video monitor through multimode (MM) or single mode (SM) fiber. Its small form factor allows mounting directly to the camera's coax video output port. This unit incorporates two status LEDs: power and coax video RX. It operates as a coax receiver and a fiber transmitter.

- Stand-alone version only
- One SC or ST fiber transmitter port
- One 75-ohm BNC video receiver port

The J/VD-RX-01 standard size fiber receiver is a companion to the J/VD-TX-01 series transmitter. This receiver mounts into Transition's E-MCR-04 12-position rack-mount shelf. This unit incorporates two status LEDs: power status and fiber video RX. It operates as a fiber receiver and a coax transmitter to a monitor.

- Stand-alone version only
- One SC or ST fiber receiver port
- One 75-ohm BNC video transmitter port

J/VD-RX-01

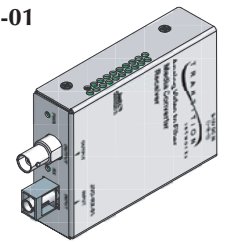

J/VD-MRX-01

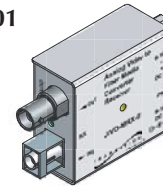

The J/VD-MRX-01 small-form-factor fiber receiver is a similar sized companion to the J/VD-TX-01 series transmitter. This unit incorporates two status LEDs: power and fiber video RX. It operates as a fiber receiver and a coax transmitter to a monitor.

- Stand-alone version only
- One SC or ST fiber receiver port
- One 75-ohm BNC video transmitter port

Installation	3
Operation	4
Cable Specification	4
Technical Specifications	5
Troubleshooting	6
Contact Us	7
Compliance Information	8

The video transmitter/receiver system has the following copper connections.

Connector Type	Number	Description
75-Ohm BNC	2	75-Ohm coax cable, 30.5 m (100ft)

The various fiber connections are available on separate models. Single mode and multimode units come in the following configurations.

Model	Optic Fiber	Distance	Form Factors
J/VD-TX-01	ST, multimode, 850 nm	1km (0.62miles)	Min*
J/VD-RX-01	ST, multimode, 850 nm	1km (0.62miles)	Std*
J/VD-MRX-01	ST, multimode, 850 nm	1km (0.62miles)	Min
J/VD-TX-01(SC)	SC, multimode, 850 nm	1km (0.62miles)	Min
J/VD-RX-01(SC)	SC, multimode, 850 nm	1km (0.62miles)	Std
J/VD-MRX-01(SC)	SC, multimode, 850 nm	1km (0.62miles)	Min
J/VD-TX-01(SM)	ST, single mode, 1310 nm	10km (6.21miles)	Min
J/VD-RX-01(SM)	ST, single mode, 1310 nm	10km (6.21miles)	Std
J/VD-MRX-01(SM)	ST, single mode, 1310 nm	10km (6.21miles)	Min

*Standard (Std), Miniature (Min)

Accessories

The WMBS wall-mount bracket is for the J/VD-RX-01 receiver only.

Part Number	Description
WMBS	Wall-Mount Bracket, L 98.96 mm (3.896 in.) W: 25.4 mm (1 in.)

The WMBJ-V wall-mount bracket is for the J/VD-TX-01 transmitter and J/VD-MRX-01 receiver only.

Part Number	Description
WMBJ-V	Wall-Mount Bracket, L 69.9 mm (2.75 in) W: 63.5 mm (2.5 in)

Additional Accessories

For the J/VD-RX-01 receiver only.

Part Number	Description
SPS-1872-CC	Piggy back power supply 48 VDC in, 12VDC out
SPS-1872-SA	Stand-alone power supply 48 VDC in, 12VDC out
E-MCR-04	Twelve (12) slots for Transition Networks’ stand-alone media converters requiring an external power supply. Dimensions 3.0 in. high x 1.0 in. wide x 4.7 in. deep (76 mm x 25 mm x 119 mm).

Installation

Connecting power

Transmitter and receiver back panels:

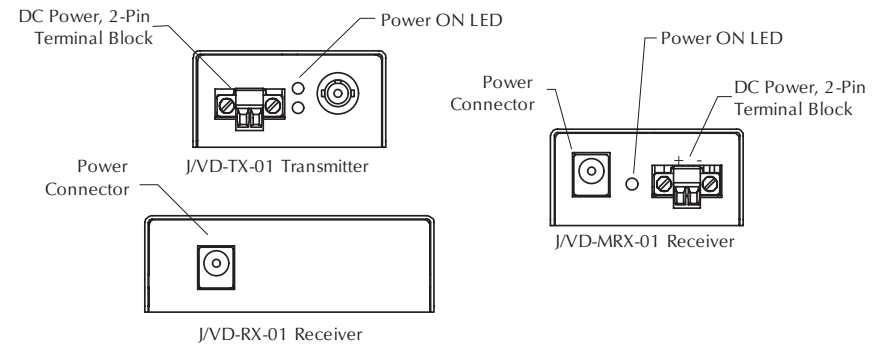

Video System Back Panels

Note: J/VD-MRX-01 receiver has two ways to connect power: barrel connector and a polarity sensitive 2-pin terminal block.

Note: The video transmitter and receiver must be matched: single mode TX/RX or multimode TX/RX. If installed as a mixed pair, the system will not function.

Caution: Use 75 ohm BNC connectors on 75 ohm cable only. Failure to observe this caution will result in signal degradation.

To install the video transmitter and receiver system cables, see installation diagram below:

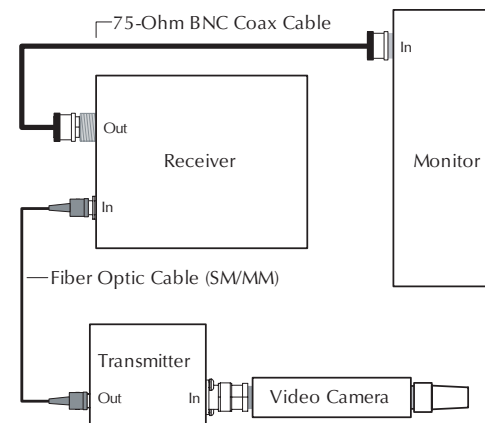

Operation

- Make sure that power is supplied to the transmitter, receiver, and camera, with the monitor turned ON.
- The system is operational when what the camera sees appears on the monitor.

Cable specifications

Coax cable

RG Type:	RG-59, RG-6
Gauge:	18–25, single conductor
Impedance:	75 ohms
Distance:	30.48 M (100 ft) Max

Fiber

Single Mode	9/125 μ
Multimode	62.5/125 μ

Multimode

Wavelength:	850 nm
Link Budget:	6.0 db

Single Mode

Wavelength:	1310 nm
Link Budget:	10.0 db

Technical Specifications

Use 75 ohm BNC connectors on 75 ohm cable only.

Transition Networks models J/VD-TX-01, J/VD-RX-01, J/VD-MRX-01 video system specifications for all three models.

Video formats: NTSC, PAL, SECAM

Video spec

Input Video:	0.5 to 2-volt pk-pk (75 ohms)
Bandwidth:	5 Hz - 10 MHz
Differential gain:	< 5 %
Differential phase:	< 5°
Tilt:	<1%
Signal/Noise Ratio:	60dB

Regulatory compliance

Emissions: EN55022 class A
Immunity: EN55024

Safety compliance: Unit: CE Mark

Power supply: UL listed

Power consumption: 2 watts

Power input range: 9 – 40VDC; 9 – 24VAC (TX)
9 – 16 VAC/VDC (RX)

Power supply: External wall-mount AC/DC; 12VDC @ 0.5A

Operating temperature: 0°C to 50°C (32°F to 140°F) with included AC/DC power supply

-40°C to 75°C (-40°F to 176°F) DC voltage input

Storage temperature: -25°C to 85°C (13°F to 185°F)

Humidity: 5% to 95%, non-condensing

Altitude: 0 to 10,000 feet

Dimensions: TX: 2.0" x 2.2" x 1.0" (50.8 mm, 55.88 mm, 25.4 mm)
RX: 3.0" x 3.896" x 1.0" (76.2 mm, 98.96 mm, 25.4 mm)
MRX: 2.0" x 2.2" x 1.0" (50.8 mm, 55.88 mm, 25.4 mm)

Warranty: Lifetime

The information in this user's guide is subject to change. For the most up-to-date information on the J/VD-TX-01, J/VD-RX-01, J/VD-MRX-01 video system, view the user's guide on-line at: www.transition.com.

Troubleshooting

If there are problems with the system setup or a system failure occurs, isolate and correct the problem by determining the answers to the following questions and then taking the indicated action:

1. Are the power LEDs ON in the transmitter and receiver?

NO

- Are the power adapters the proper type (*voltage and frequency*) for the AC outlet?
- Are the power cords properly plugged/installed into the transmitter and receiver, and plugged into an active electrical outlet?
- Contact Technical Support: US/Canada: 1-800-260-1312, International: 00-1-952-941-7600.

YES

- Proceed to step 2.

2. Are the RX LEDs lit on the transmitter and receiver?

NO

- Check that the fiber cable SM/MM matches the transmitter and receiver set SM/MM.
- Check the fiber-cable connections and condition of the fiber cable.
- Check for video signal at the transmitter coax port.
- Check the coax cable connection.
- Contact Technical Support: US/Canada: 1-800-260-1312, International: 00-1-952-941-7600.

Yes

- Contact Technical Support: US/Canada: 1-800-260-1312, International: 00-1-952-941-7600.

Contact Us

Technical support

Technical support is available 24 hours a day.

US and Canada: 1-800-260-1312

International: 00-1-952-941-7600

Transition now

Chat live via the Web with Transition Networks Technical Support.

Log onto www.transition.com and click the Transition Now link.

Web-based seminars

Transition Networks provides seminars via live web-based training.

Log onto www.transition.com and click the Learning Center link.

E-Mail

Ask a question anytime by sending an e-mail to our technical support staff.



techsupport@transition.com

Address

Transition Networks

6475 City West Parkway, Minneapolis, MN 55344, U.S.A.

telephone: 952-941-7600, toll free: 800-526-9267, fax: 952-941-2322

		Declaration of Conformity
Name of Mfg:	Transition Networks 6475 City West Parkway, Minneapolis MN 55344 U.S.A.	
Model:	J/VD-TX-01, J/VD-RX-01, J/VD-MRX-01 Video Transmitter and Receivers	
Part Number(s):	J/VD-TX-0X, J/VD-RX-01, J/VD-MRX-01	
Regulation:	EMC Directive 89/336/EEC	
Purpose:	To declare that the J/VD-xxx-01 to which this declaration refers is in conformity with the following standards. CISPR 22:1997+A1:2000; EN 55024:1998+A1:2000 Class A; FCC part 15 subpart B; CFR 21 subpart J	
I, the undersigned, hereby declare that the equipment specified above conforms to the above Directive(s) and Standard(s).		
 Stephen Anderson, Vice-President of Engineering		<u>OCT 7, 2005</u> Date

Compliance Information

CISPR22/EN55022 Class A

CE Mark

FCC regulations

This equipment has been tested and found to comply with the limits for a class A digital device, pursuant to part 15 of the FCC rules. These limits are designed to provide reasonable protection against harmful interference when the equipment is operated in a commercial environment. This equipment generates, uses, and can radiate radio frequency energy and, if not installed and used in accordance with the instruction manual, may cause harmful interference to radio communications. Operation of this equipment in a residential area is likely to cause harmful interference, in which case the user will be required to correct the interference at the user's own expense.

Canadian regulations

This digital apparatus does not exceed the Class A limits for radio noise for digital apparatus set out on the radio interference regulations of the Canadian Department of Communications.
Le présent appareil numérique n'émet pas de bruits radioélectriques dépassant les limites applicables aux appareils numériques de la class A prescrites dans le Règlement sur le brouillage radioélectrique édicté par le ministère des Communications du Canada.

European regulations

WARNING: This is a Class A product. In a domestic environment this product may cause radio interference in which case the user may be required to take adequate measures.

ACHTUNG! Dieses ist ein Gerät der Funkstörgrenzwertklasse A. In Wohnbereichen können bei Betrieb dieses Gerätes Rundfunkstörungen auftreten. In diesem Fall ist der Benutzer für Gegenmaßnahmen verantwortlich.

ATTENTION! Ceci est un produit de Classe A. Dans un environnement domestique, ce produit risque de créer des interférences radioélectriques, il appartiendra alors à l'utilisateur de prendre les mesures spécifiques appropriées.



In accordance with European Union Directive 2002/96/EC of the European Parliament and of the Council of 27 January 2003, Transition Networks will accept post usage returns of this product for proper disposal. The contact information for this activity can be found in the 'Contact Us' portion of this document.



CAUTION: RJ connectors are NOT INTENDED FOR CONNECTION TO THE PUBLIC TELEPHONE NETWORK. Failure to observe this caution could result in damage to the public telephone network.

Der Anschluss dieses Gerätes an ein öffentliches Telekommunikationsnetz in den EG-Mitgliedstaaten verstösst gegen die jeweiligen einzelstaatlichen Gesetze zur Anwendung der Richtlinie 91/263/EWG zur Angleichung der Rechtsvorschriften der Mitgliedstaaten über Telekommunikationsendeinrichtungen einschliesslich der gegenseitigen Anerkennung ihrer Konformität.

Trademark notice

All trademarks and registered trademarks are the property of their respective owners.

Copyright restrictions

© 2003, 2005 Transition Networks.

All rights reserved. No part of this work may be reproduced or used in any form or by any means - graphic, electronic, or mechanical - without written permission from Transition Networks.