

User's Guide
CFMFF4040-100
Optical Line Converter for
Small Form Factor Pluggable (SFP)
Transceiver Modules

The Transition Networks CFMFF4040-100 optical line converter is designed to accommodate two (2) small form factor pluggable (SFP) transceiver modules; and install into the Transition Networks *PointSystem™* chassis.

The following SFP transceiver modules are compatible with the CFMFF4040-100 converter and are available from Transition Networks (*sold separately*).

	Port 1	Port 2
CFMFF4040-100	empty	empty
Part Number	Description	
TN-SFP-SX	LC, 1000Base-SX, 850 nm multimode, 220-500 m (720-1640 ft)*	
TN-SFP-LX1	LC, 1000Base-LX, 1310 nm single mode, 10 km (6.2 miles)* with DMI	
TN-SFP-LX3	LC, 1000Base-LX, 1310 nm single mode, 30 km (18.8 miles)* with DMI	
TN-SFP-LX5	LC, 1000Base-LX, 1550 nm single mode, 50 km (31.2 miles)* with DMI	
TN-SFP-LX8	LC, 1000Base-LX, 1550 nm single mode, 80 km (50.0 miles)* with DMI	
TN-SFP-LX12	LC, 1000Base-LX, 1550 nm single mode, 120 km (74.56 miles)* with DMI	

Installation	3
Operation	5
Diagnostic Monitor Interface (DMI)	7
Technical Specifications	8
Troubleshooting	9
Contact Us	10
Compliance Information	11

Optical line converter -- continued

The following SFP transceiver modules are compatible with the CFMFF4040-100 converter and are available from Transition Networks (*sold separately*).

Part number	Duplex Fiber Optic
TN-SFP-OC3M	LC, 100Base-FX/OC-3 SFP 1300 nm multimode 2km (1.2 miles)* with DMI
TN-SFP-OC3S	LC, 100Base-FX/OC-3 SFP 1310 nm single mode 20km (12.4miles)* with DMI
TN-SFP-OC12M	LC, OC-12/STM-4 SFP 1300 nm multimode 1 km (0.6 miles)* with DMI
TN-SFP-OC12S	LC, OC-12/STM-4 SFP 1310 nm single mode 20 km (12.4 miles)* with DMI
TN-SFP-FC2XM	LC, 2x/1x/OC-48/STM-16/1000Base-SX, 850 nm multimode, DMI, 150 m (492 ft)* on 62.5/125 µm fiber, 300 m (984ft)* on 50/125 µm fiber
TN-SFP-FC2XS2	LC, 2x/1x/OC-48/STM-16/1000Base-LX, 1310 nm single mode, 2 km (1.2 miles)* with DMI
TN-SFP-FC2XS15	LC, 2x/1x/OC-48/STM-16/1000Base-LX, 1310 nm single mode, 15 km (9.3 miles)* with DMI
TN-SFP-FC2XS40	LC, 2x/1x/OC-48/STM-16/1000Base-LX, 1310 nm single mode, 40 km (24.9 miles)* with DMI

*Unless otherwise indicated, the distances listed are the typical maximum cable distance. The actual maximum cable distances are dependent upon the physical characteristics of the network installation.

With any two Transition Networks SFP transceiver modules installed, the CFMFF4040-100 converter can perform the following mode conversions:

- multimode to multimode
- multimode to single mode
- single mode to single mode

Also the following wavelength line conversions:

- 850 nm to 850 nm
- 850 nm to 1310 nm
- 850 nm to 1550 nm
- 1310 nm to 850 nm
- 1310 nm to 1310 nm
- 1310 nm to 1550 nm
- 1550 nm to 850 nm
- 1550 nm to 1310 nm
- 1550 nm to 1550 nm
- CWDM (*coarse wavelength division multiplexing*)
- DWDM (*dense wavelength division multiplexing*)

Installation

Set the HW/SW Jumper

- The jumper is located on the circuit board, labeled "J1".
- Use needle-nose pliers to set the jumper.

Hardware: The media converter settings can be monitored using SNMP, but cannot be managed.

Software: The media converter settings are monitored and managed using SNMP.

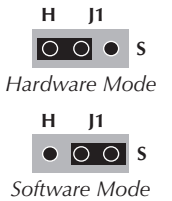

Install the Slide-In-Module

IMPORTANT: Slots in the PointSystem™ chassis that do not have a module installed MUST have a protective plate covering the empty slot for Class A and/or Class B compliance.

Note: The slide-in-modules may be inserted in any slot and in any order.

To install the CFMFF4040-100 optical line converter:

1. Locate an empty installation slot on the *PointSystem*™ chassis.
2. Carefully slide the converter into the slot, aligning it with the installation guides.
3. Ensure that the module is firmly seated inside the chassis.
4. Push in and rotate the attached panel fastener screw clockwise to secure the module to the chassis front.

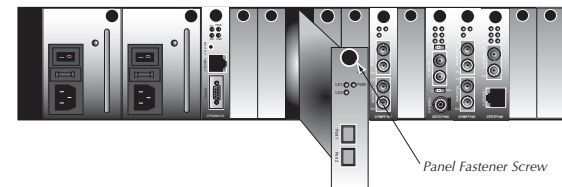

Installation -- continued

Power the Media Converter

The CFMFF4040-100 optical line converter is powered through the Transition Networks *PointSystem*™ chassis.

Install SFP Transceiver Modules

To install SFP transceiver modules into the CFMFF4040-100 converter:

1. Position the SFP transceiver module at the installation slot so that the label faces to the right.
2. Carefully slide the module into one of the installation slots, aligning the module with the internal installation guides.
3. Ensure that the module is firmly seated against the internal mating connector.
4. Repeat steps 1 thru 3 to install a module into the second slot.

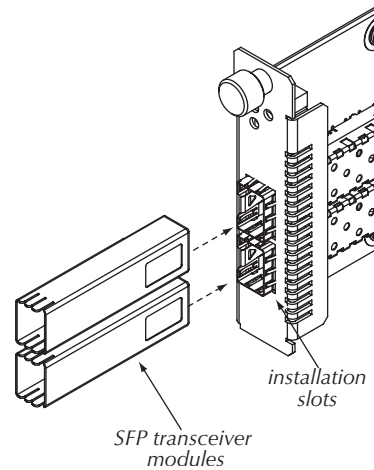

Remove SFP Transceiver Modules

To remove a SFP transceiver module from the CFMFF4040-100 converter:

1. Swing the handle on the SFP transceiver to the "out" position, shown to the right.
2. Carefully pull the module outward until it separates from the converter.

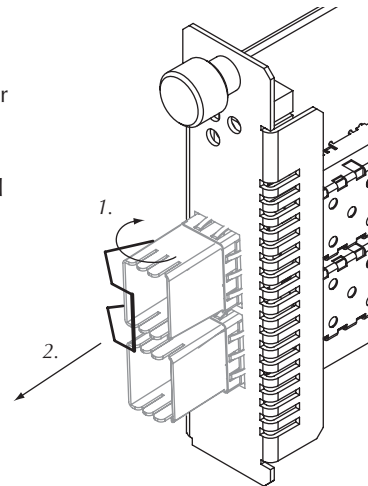

Operation

Status LEDs

The CFMFF4040-100 optical line converter is designed to operate without user intervention. Use the status LEDs to monitor the operation of the converter in the network.

PWR (Power) On = Connection to external power.

LK1 (Fiber Link 1) On = Fiber port 1 is receiving a signal.

LK2 (Fiber Link 2) On = Fiber port 2 is receiving a signal.

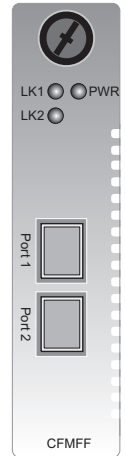

Link Pass-Through

The Link Pass-Through feature allows the media converter to monitor both fiber RX (receive) ports for loss of signal. In the event of an RX signal loss (1), the media converter will automatically disable the TX (transmit) signal (2), thus, "passing through" the link loss (3). The far-end device is automatically notified of the link loss (4), which prevents the loss of valuable data unknowingly transmitted over an invalid link.

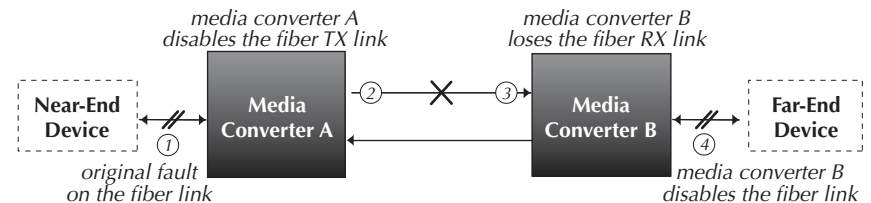

Note: Link losses will be automatically repaired by the converters.

Operation -- continued

SNMP

Use SNMP at an attached terminal or at a remote location to supervise the media converter by monitoring:

- Media converter power*
- Presence of SFP modules
- Fiber link status
- SFP vendor and model*
- Media converter temperature*
- TX/RX power*

Also, use SNMP to enter network commands that:

- Turn ON/OFF the media converter
- Turn ON/OFF the SFP ports

See the on-line documentation that comes with Transition Networks *FocalPoint*™ software for applicable commands and usage at www.transition.com.

* Some third-party manufacturers of SFP modules might not provide these features in their product. If this is the case, the *FocalPoint*™ software will not display these features.

Diagnostic Monitoring Interface (DMI)

The following DMI port screen and explanation table contains brief definitions of the DMI support offered on Transition Networks SFP optical interfaces. For further information, please see the help option on the CPSMM-xxx SNMP agent or Focal Point, Transition Networks' GUI.

DMI RX Power 210 <input type="text"/> uW -6.778 <input type="text"/> dBm	DMI RX Power Alarm <input checked="" type="checkbox"/> Normal <input type="checkbox"/> Low Warn <input type="checkbox"/> High Warn <input type="checkbox"/> Low Alarm <input type="checkbox"/> High Alarm
DMI Temp 30.1 <input type="text"/> °C 86.2 <input type="text"/> °F	DMI Temp Alarm <input checked="" type="checkbox"/> Normal <input type="checkbox"/> Low Warn <input type="checkbox"/> High Warn <input type="checkbox"/> Low Alarm <input type="checkbox"/> High Alarm
DMI Bias Current 20 <input type="text"/> uA	DMI Bias Alarm <input type="checkbox"/> Normal <input type="checkbox"/> Low Warn <input type="checkbox"/> High Warn <input type="checkbox"/> Low Alarm <input type="checkbox"/> High Alarm
DMI TX Power 0 <input type="text"/> uW 0.000 <input type="text"/> dBm	DMI TX Power Alarm <input type="checkbox"/> Normal <input type="checkbox"/> Low Warn <input type="checkbox"/> High Warn <input checked="" type="checkbox"/> Low Alarm <input type="checkbox"/> High Alarm
Rx Power Intrusion Threshold 1000 <input type="text"/> uW 0.000 <input type="text"/> dBm	<input checked="" type="checkbox"/> Intrusion Detected

Variable Name	Description
DMI Rx Power	Measured Receive optical power in microwatts and in decibels relative to 1mW.
DMI Rx Power Alarm	Alarm status of measured Receive optical power.
DMI Temp	Internally measured temperature of transceiver in degrees C and degrees F.
DMI Temp Alarm	Alarm status for internally measured temperature of transceiver.
DMI Bias Current	Measured transmit bias current in microamperes.
DMI Bias Alarm	Alarm status for measured transmit bias current for the interface.
DMI Tx Power	Measured transmit power, in microwatts and in decibels relative to 1mW..
DMI Tx Power Alarm	Alarm status of measured transmit power.
Rx Power Intrusion Threshold	<p>Instructs the converter to stop passing traffic when the receive power drops below the new threshold. This feature is sometimes referred to as 'Intrusion Detection,' since tapping into a fiber to intercept traffic leads to a reduction in receive power. This value can be entered in microwatts or in decibels relative to 1mW.</p> <p>Note: This feature is not available on all devices.</p>

Technical Specifications

For use with Transition Networks model CFMFF4040-100 or equivalent.

Standards	MSA (<i>Multi-Source Agreement</i>) compliant SFP (<i>Small Form Factor Pluggables</i>)
Dimensions	3.4 x 5.0 x 0.87 (<i>86 x 182 x 22 mm</i>)
Weight	3 oz. (<i>91 g</i>) approximately
Power consumption	2.0 Watts with two (2) Transition Networks SFPs installed (<i>Power consumption depends on the type of SFPs installed.</i>)

Environment

Tmra*:	-10° to 60°C (<i>14° to 185°F</i>)
Storage Temp:	-40° to 85°C (<i>14° to 185°F</i>)
Humidity:	5 to 95%, non-condensing
Altitude:	0 to 10,000 feet
Warranty	Lifetime

*Manufacturer's rated ambient temperature: "Tmra" range for this slide-in-module depends on the physical characteristics and the installation configuration of the Transition Networks PointSystem™ chassis in which this slide-in-module will be installed.

The information in this user's guide is subject to change. For the most up-to-date information on the CFMFF4040-100 optical line converter, view the user's guide on-line at: www.transition.com.

The stand-alone version of this media converter is SFMFF4040-100. For more information, see the SFMFF4040-100 user's guide on-line at: www.transition.com.

Troubleshooting

If the CFMFF4040-100 converter fails, isolate and correct the failure by determining the answers to the following questions and taking the indicated action:

- Is the PWR (*power*) LED illuminated?
 - NO
 - Ensure the converter is inserted properly into the chassis.
 - Ensure the power cord is properly installed in the chassis and in the grounded outlet.
 - Ensure the grounded outlet provides power.
 - Contact Technical Support: US/Canada: 1-800-260-1312, International: 00-1-952-941-7600.
 - YES
 - Proceed to step 2.
- Are both LK1 & LK2 LEDs (*fiber link for ports 1 & 2*) illuminated?
 - NO
 - Ensure both SFP transceiver modules are properly inserted in the converter.
 - Check the fiber cables for proper connection.
 - Verify that the TX and RX cables on the media converter are connected to the RX and TX ports, respectively, on the other device.
 - Contact Technical Support: US/Canada: 1-800-260-1312, International: 00-1-952-941-7600.
 - YES
 - Proceed to step 3.
- Is the LK1 LED (*fiber link 1*) flashing?
 - NO
 - If there is no network activity on port 1, proceed to step 4.
 - If there is network activity on port 1, disconnect and reconnect the fiber cables to restart the initialization process.
 - Contact Technical Support: US/Canada: 1-800-260-1312, International: 00-1-952-941-7600.
 - YES
 - Proceed to step 4.
- Is the LK2 LED (*fiber link 2*) flashing?
 - NO
 - If there is no network activity on port 2, contact technical support.
 - If there is network activity on port 2, disconnect and reconnect the fiber cables to restart the initialization process.
 - Contact Technical Support: US/Canada: 1-800-260-1312, International: 00-1-952-941-7600.

Contact Us

Technical support

Technical support is available 24 hours a day.

US and Canada: 1-800-260-1312

International: 00-1-952-941-7600

Transition now

Chat live via the Web with Transition Networks Technical Support.

Log onto www.transition.com and click the Transition Now link.

Web-based seminars

Transition Networks provides seminars via live web-based training.

Log onto www.transition.com and click the Learning Center link.

E-Mail

Ask a question anytime by sending an e-mail to our technical support staff.

techsupport@transition.com

Address

Transition Networks

6475 City West Parkway

Minneapolis, MN 55344, U.S.A.

telephone: 952-941-7600

toll free: 800-526-9267

fax: 952-941-2322



Declaration of Conformity

Name of Mfg: Transition Networks
6475 City West Parkway, Minneapolis MN 55344 U.S.A.

Model: CFMFF4040-100 SFP Optical Line Converter

Part Number: CFMFF4040-100

Regulation: EMC Directive 89/336/EEC

Purpose: To declare that the CFMFF4040-100 to which this declaration refers is in conformity with the following standards.

EN 55022:1998 Class A; EN 55024:1998+A1+A13564:2002; FCC Part 15 subpart B; 21CFR subpart J

I, the undersigned, hereby declare that the equipment specified above conforms to the above Directive(s) and Standard(s).

Stephen Anderson, Vice-President of Engineering

June 6, 2006
Date

Compliance Information

CISPR22/EN55022 Class A + EN55024; CE Mark

FCC regulations

This equipment has been tested and found to comply with the limits for a Class A digital device, pursuant to part 15 of the FCC rules. These limits are designed to provide reasonable protection against harmful interference when the equipment is operated in a commercial environment. This equipment generates, uses, and can radiate radio frequency energy and, if not installed and used in accordance with the instruction manual, may cause harmful interference to radio communications. Operation of this equipment in a residential area is likely to cause harmful interference, in which case the user will be required to correct the interference at the user's own expense.

Canadian regulations

This digital apparatus does not exceed the Class A limits for radio noise for digital apparatus set out on the radio interference regulations of the Canadian Department of Communications. Le présent appareil numérique n'émet pas de bruits radioélectriques dépassant les limites applicables aux appareils numériques de la Class A prescrites dans le Règlement sur le brouillage radioélectrique édicté par le ministère des Communications du Canada.

European regulations

Warning This is a Class A product. In a domestic environment this product may cause radio interference in which case the user may be required to take adequate measures.

Achtung! Dieses ist ein Gerät der Funkstörgrenzwertklasse A. In Wohnbereichen können bei Betrieb dieses Gerätes Rundfunkstörungen auftreten. In diesem Fall ist der Benutzer für Gegenmaßnahmen verantwortlich.

Attention! Ceci est un produit de Classe A. Dans un environnement domestique, ce produit risque de créer des interférences radioélectriques, il appartiendra alors à l'utilisateur de prendre les mesures spécifiques appropriées.



In accordance with European Union Directive 2002/96/EC of the European Parliament and of the Council of 27 January 2003, Transition Networks will accept post usage returns of this product for proper disposal. The contact information for this activity can be found in the 'Contact Us' portion of this document.



CAUTION: RJ connectors are NOT INTENDED FOR CONNECTION TO THE PUBLIC TELEPHONE NETWORK. Failure to observe this caution could result in damage to the public telephone network.

Der Anschluss dieses Gerätes an ein öffentliches Telekommunikationsnetz in den EG-Mitgliedstaaten verstößt gegen die jeweiligen einzelstaatlichen Gesetze zur Anwendung der Richtlinie 91/263/EWG zur Angleichung der Rechtsvorschriften der Mitgliedstaaten über Telekommunikationsendeinrichtungen einschliesslich der gegenseitigen Anerkennung ihrer Konformität.

Trademark notice

All trademarks and registered trademarks are the property of their respective owners.

Copyright restrictions

© 2004 Transition Networks.

All rights reserved. No part of this work may be reproduced or used in any form or by any means—graphic, electronic, or mechanical—without written permission from Transition Networks.