



## SEPOE10xx-150 User's Guide

- **Stand-Alone Media Converter**
- **Power Over Ethernet**
- **10Base-T to 10Base-FL**

The SEPOE10xx-150 Power Over Ethernet (POE) is a 10Base-T to 10Base-FL media converter capable of providing power to Data Terminal Equipment (DTE) Power Devices (PD) via the Media Dependent Interface (MDI) twisted pair cable. The SEPOE10xx-150 emulates Power Sourcing Equipment (PSE) and is compatible with Powered Devices (PD) that comply with the IEEE802.3af™ standard. The SEPOE10xx-150 also includes Transition Networks' proprietary PD signature sensing and power monitoring features.

<b>Part Number</b>	<b>Port One - Copper 10Base-T</b>	<b>Port Two - Duplex Fiber-Optic 10Base-FL</b>
<b>SEPOE1011-150</b>	RJ-45 100 m (328 ft.)*	ST, 850 nm multimode 2 km (1.2 miles)*
<b>SEPOE1012-150</b>	RJ-45 100 m (328 ft.)*	ST, 1310 nm singlemode 20 km (12.4 miles)*
<b>SEPOE1013-150</b>	RJ-45 100 m (328 ft.)*	SC, 850 nm multimode 2 km (1.2 miles)*
<b>SEPOE1014-150</b>	RJ-45 100 m (328 ft.)*	SC, 1310 nm singlemode 20 km (12.4 miles)*

\* Typical maximum cable distance. Actual distance is dependent upon the physical characteristics of the network installation.

### Optional Accessories (sold separately)

<b>Part Number</b>	<b>Description</b>
<b>WMBL</b>	Optional Wall Mount Brackets Length: 4.0 in. (102 mm), Fits converter length: 4.7 in. (119 mm)
<b>WMBD</b>	Optional DIN Rail Mount Bracket; Length: 5.0 in. (127 mm)
<b>WMBD-F</b>	Optional DIN Rail Mount Bracket (flat); Length: 3.3in. (84 mm)

Installation . . . . .	2
Maintenance . . . . .	5
Operation . . . . .	6
Cable Specifications . . . . .	8
Technical Specifications . . . . .	9
Troubleshooting . . . . .	9
Compliance Information . . . . .	12

## Installation and Service

**ALL INSTALLATION AND SERVICE MUST BE PERFORMED BY QUALIFIED SERVICE PERSONNEL.**

Read and follow all warning notices and instructions marked on the product or included in the manual

**CAUTION: Ensure that the power source is NOT powered when connecting it to the SEPOE10xx-150 series media converter. Failure to observe this caution could result in damage to, and subsequent failure of, the SEPOE10xx-150.**

### Required Grounding

Proper earthing (grounding) of the SEPOE10xx-150 is required. A grounding terminal is provided on the SEPOE10xx-150 for proper grounding of the device as per customer installation requirements and local electrical codes.

The DC-powered, SEPOE10xx-150 series media converter is intended to be used in a restricted access location. It is recommended that the 18-72 VDC source is to be reliably connected to earth (ground). Equipment grounding is vital to ensure safe operation.

Prior to installation, use a voltmeter/ohmmeter to check the wiring for the presence of earth ground.

### Required Disconnect

A readily accessible disconnect device as part of the building installation shall be incorporated into the fixed wiring for the SEPOE10xx-150 series media converter. The disconnect device (a -48 VDC, 15 or 20A circuit breaker or switch) must be included in the ungrounded supply conductor. Overcurrent protection must be a -48 VDC, 15 or 20A fuse or circuit breaker.

## Installation -- Continued

**CAUTION: Both the fiber and copper connections to the SEPOE10xx-150 media converter must be of the same network speed and network protocol. Failure to observe this caution will cause data transfer to fail.**

### Install the Fiber Cable

1. Locate or build 10Base-FL compliant fiber cable with male, two-stranded TX to RX connectors installed at both ends.
2. Connect the fiber cables to the SEPOE10xx-150 media converter as described:
  - Connect the male **TX** cable connector to the female **TX** port.
  - Connect the male **RX** cable connector to the female **RX** port.
3. Connect the fiber cables to the other device (another media converter, hub, etc.) as described:
  - Connect the male **TX** cable connector to the female **RX** port.
  - Connect the male **RX** cable connector to the female **TX** port.

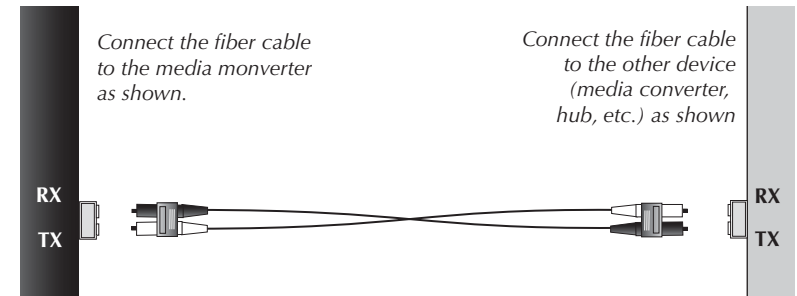

### Install the Copper Cable

1. Locate or build 10Base-T compliant copper cables with male, RJ-45 connectors installed at both ends.
2. Connect the RJ-45 connector at one end of the cable to the RJ-45 port on the SEPOE10xx-150 media converter.
3. Connect the RJ-45 connector at the other end of the cable to the RJ-45 port on the powered device.



## Installation -- Continued

### Supplying Power to the SEPOE10xx-150

The SEPOE10xx-150 features under voltage lockout, which disables operation and eliminates excessive power draw from the 48 volt external power source if the source falls below approximately 44 VDC.

**CAUTION: The power source MUST BE POWERED OFF when connecting it to the SEPOE10xx-150. Failure to observe this caution could result in damage to, and subsequent failure of, the power supply and any attached device.**

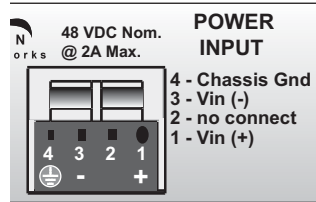

1. Ensure that external power source is powered OFF.
2. Connect the positive (+) terminal of the power supply to the positive terminal on the SEPOE10xx-150 (marked with a "1").
3. Connect the negative (-) terminal of the power supply to the negative terminal on the SEPOE10xx-150 (marked with a "3").
4. Connect the ground terminal of the power supply (or an appropriate 'earthing' ground location) to the ground terminal on the SEPOE10xx-150 (marked with a "4").
5. Turn on the power to the external power source.
6. Verify that the SEPOE10xx-150 is powered by observing the illuminated power LED.

### Disconnecting Power to the SEPOE10xx-150

**CAUTION: The power source MUST BE POWERED OFF when disconnecting it from the SEPOE10xx-150. Failure to observe this caution could result in damage to, and subsequent failure of, the power supply and any attached device.**

1. Ensure that external power source is powered OFF.
2. Disconnect the positive (+) terminal of the power supply from the positive terminal on the SEPOE10xx-150 (marked with a "1").
3. Disconnect the negative (-) terminal of the power supply from the negative terminal on the SEPOE10xx-150 (marked with a "3").
4. Disconnect the ground terminal of the power supply (or the 'earth' ground) from the ground terminal on the SEPOE10xx-150 (marked with a "4").

## Maintenance

### Replacing Power Supply Module Fuse

Catastrophic fault protection is provided by an internal 2 Amp fuse.

**CAUTION: Failure to observe the following cautions could result in damage to, and subsequent failure of, the SEPOE10xx-150 media converter, the external power supply, and any attached device.**

- Wear a grounding device and observe electrostatic discharge precautions when replacing the fuse in this device.
- Replace the fuse only with the same size and rating.
- Ensure that the power source is NOT powered when disconnecting power from, or connecting power to, this device.

To replace the fuse in the SEPOE10xx-150:

1. Ensure that the external power source is not powered.
2. Disconnect the SEPOE10xx-150 from the external power source (see page 5).
3. Remove and retain the screws that secure the cover to the SEPOE10xx-150. Remove and retain the cover to the device.

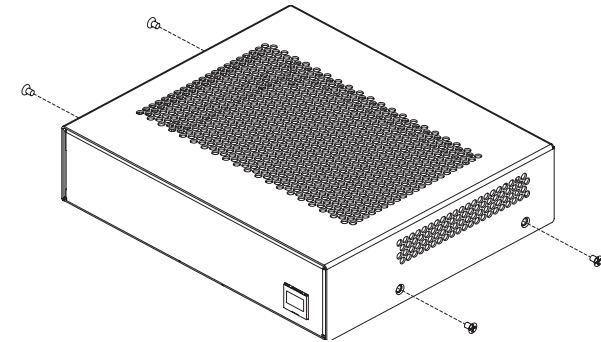

4. Carefully remove the fuse from the fuse holder.
5. Install the **same size and rating** replacement fuse in the fuse holder.
6. Replace the cover to the SEPOE10xx-150 and install the screws.
7. Reconnect the SEPOE10xx-150 to the external power source (see page 4).

Product is certified by the manufacturer to comply with DHHS Rule 21/CFR, Subchapter J applicable at the date of manufacture.

**CAUTION: Visible and Invisible Laser Radiation When Open. Do Not Stare Into Beam Or View Directly With Optical Instruments.**

**CAUTION: Use of controls, adjustments or the performance of procedures other than those specified herein may result in hazardous radiation exposure.**

## Operation

### LED Indicators

After installation, the media converter should function without operator intervention. Use the status LEDs to monitor media converter operation in the network.

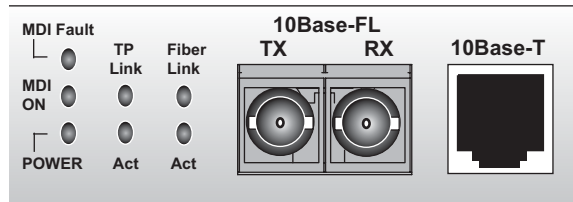

- MDI Fault** On (for 5-10 seconds) = the POE sources exceed approximately **0.4 A\*** of current on the MDI interface.
- MDI ON** On = the current to the MDI that is greater than approximately 10 mA or less than approximately **0.4 A\***. Power to the MDI is removed if the current is outside this range.  
*(\*Including the in-rush current required to charge the PD (Powered Device) load capacitance.)*
- POWER** On = the input voltage is above approximately 44 VDC.
- TP Link** On = a link from the twisted-pair copper connection to the Powered Device (PD).
- Fiber Link** On = a link from the fiber connection to the other media converter or remote hub.
- TP Act** Flashing = activity on the Powered Device (PD).
- Fiber Act** Flashing = activity on the other media converter or remote hub.

### Configuration Switches

Set the configurations switches as required for the network

#### MDI PWR Switch

*Enable:* Enables MDI power functions.

*Disable:* Disables MDI power functions.

#### Link Pass Thru Switch

*Enable:* Enables Link Pass-Through.

*Disable:* Disables Link Pass-Through.

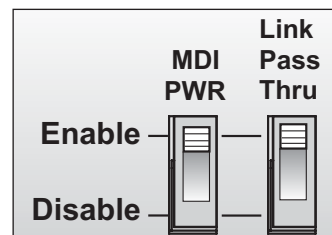

## Operation -- Continued

### MDI Power

MDI power can be activated using the MDI PWR switch on the front panel (see page 6).

MDI (Media Dependent Interface) power is provided on the spare pins of the RJ-45 connector as described by the IEEE802.3af™ standard (pin numbers 4, 5, 7, and 8). The SEPOE10xx-150 power delivery capacity is approximately 0.25 A at 48 VDC.

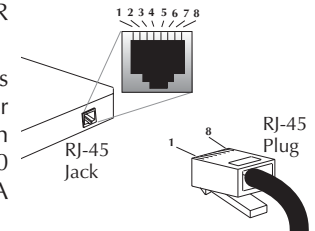

The SEPOE10xx-150 has a current sensing feature. If the load presented to the MDI is less than approximately 10 mA or greater than approximately **0.4 A\***, MDI power is removed from the interface.

MDI power insertion is initiated when the impedance of the MDI power interface falls below approximately 300 K ohms. MDI power is applied for approximately 1.1 seconds. If the current load does not remain above approximately 10 mA within this time (or if the current load is above approximately **0.4 A\*** within this time) the power is removed from the MDI. An over current condition of **0.4 A\*** will illuminate the **MDI Fault LED** for a period of 5-10 seconds before the SEPOE10xx-150 reapplies MDI power. The reapplication of MDI power requires the impedance of the MDI power interface to be below approx. 300 K ohms.

*(\*Including the in-rush current required to charge the PD (Powered Device) load capacitance.)*

### Link Pass-Through

The Link Pass-Through feature (see page 6) allows the media converter to monitor both the fiber and copper RX (receive) ports for loss of signal. In the event of a loss of an RX signal on one media port, the media converter will automatically disable the TX (transmit) signal of the other media port, thus, "passing through" the link loss.

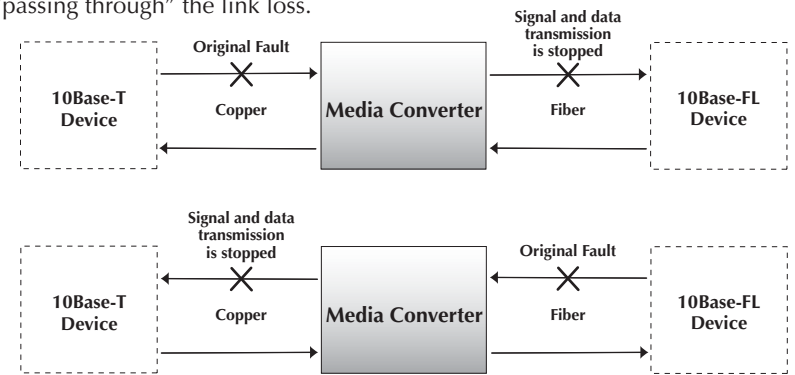

## Cable Specifications

The physical characteristics must meet or exceed IEEE 802.3™ specifications.

### Fiber Cable

Bit Error Rate:	<10 <sup>-9</sup>	
Singlemode fiber (recommended):	9 μm	
Multimode fiber (recommended):	62.5/125 μm	
Multimode fiber (optional):	100/140, 85/140, 50/125 μm	
<b>SEPOE1011-150</b>	850 nm multimode	
Fiber-optic Transmitter Power:	min: -20.0 dBm	max: -10.0 dBm
Fiber-optic Receiver Sensitivity:	min: -32.5 dBm	max: -7.2 dBm
Link Budget:	12.5 dB	
<b>SEPOE1012-150</b>	1310 nm singlemode	
Fiber-optic Transmitter Power:	min: -29.0 dBm	max: -10.0 dBm
Fiber-optic Receiver Sensitivity:	min: -35.0 dBm	max: -14.0 dBm
Link Budget:	6.0 dB	
<b>SEPOE1013-150</b>	850 nm multimode	
Fiber-optic Transmitter Power:	min: -20.0 dBm	max: -10.0 dBm
Fiber-optic Receiver Sensitivity:	min: -32.5 dBm	max: -7.2 dBm
Link Budget:	12.5 dB	
<b>SEPOE1014-150</b>	1310 nm singlemode	
Fiber-optic Transmitter Power:	min: -29.0 dBm	max: -10.0 dBm
Fiber-optic Receiver Sensitivity:	min: -35.0 dBm	max: -14.0 dBm
Link Budget:	6.0 dB	

### Copper Cable

**Category 3:** (Minimum Requirement)

Gauge	24 to 22 AWG
Attenuation	11.5 dB/100m @ 5-10 MHz

**Category 5:** (Recommended)

Gauge	24 to 22 AWG
Attenuation	22.0 dB /100m @ 100 MHz

- Straight-Through **OR** Crossover Twisted-Pair cable must be used.
- Shielded Twisted-Pair (STP) **OR** Unshielded Twisted-Pair (UTP) may be used.
- Pins 1&2 and 3&6 are the two active pairs in an Ethernet network .
- RJ-45 Pin-out: Pin 1 = TD+, Pin 2 = TD-, Pin 3 = RD+, Pin 6 = RD-
- Use only dedicated wire pairs for the active pins:  
(e.g., blue/white & white/blue, orange/white & white/orange, etc.)
- Do not use flat or silver satin wire.

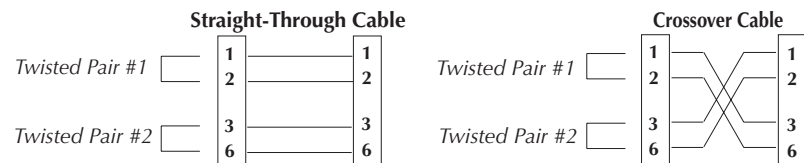

## Technical Specifications

For use with Transition Networks Model SEPOE10xx-150 or equivalent

<b>Standards</b>	IEEE 802.3™	
<b>Data Rate</b>	10 Mb/s	
<b>Dimensions</b>	7.3" x 4.4" x 1.2" (185 mm x 112 mm x 30 mm)	
<b>Weight</b>	1.6 lbs. (730 g) (approximate)	
<b>Fuse</b>	2 Amp	
<b>Power Consumption</b>	45 Watts (maximum)	
<b>Power Supply</b>	48 VDC, 1 A (typical)	
<b>Output</b>	16.8 W	
<b>Environment</b>	Tmra*:	0 to 50°C (32 to 122°F)
	Storage Temp:	-25 to 85°C (-13 to 185°F)
	Humidity:	5 to 95%, non condensing
	Altitude:	0 to 10,000 feet
<b>Warranty</b>	Lifetime	

\*Manufacturer's rated ambient temperature.

## Troubleshooting

If the media converter fails, isolate and correct the fault by determining the answers to the following questions and then take the indicated action:

- 1. Is the POWER LED on the media converter illuminated?**

**NO**

  - Ensure the external power source is properly connected to the media converter (page 4). Also ensure the power source is turned on.
  - Ensure the external power source provides power.
  - Contact Tech Support: 1-800-260-1312, Int'l: 00-1-952-941-7600.

**YES**

  - Proceed to step 2.
- 2. Is the MDI ON LED illuminated?**

**NO**

  - Ensure the Powered Device (PD) to be powered via the twisted-pair copper cable is IEEE 802.3™ Mode B compliant.
  - Ensure the proper cable (straight-through or cross over) is used.
  - Ensure the twisted-pair copper cable is a 4-pair cable.
  - Proceed to step 3.

**YES**

  - Contact Tech Support: 1-800-260-1312, Int'l: 00-1-952-941-7600.

## Troubleshooting -- Continued

### 3. Is the MDI Fault LED illuminated?

#### YES

- Ensure the Powered Device (PD) to be powered via the twisted-pair copper cable is IEEE 802.3™ Mode B compliant.
- Ensure the load to the PD is less than 0.4 amp.
- Contact Tech Support: 1-800-260-1312, Int'l: 00-1-952-941-7600.

#### NO

- Proceed to step 4.

### 4. Is the TP Link LED illuminated?

#### NO

- Check the twisted pair cables for proper installation.
- Contact Tech Support: 1-800-260-1312, Int'l: 00-1-952-941-7600.

#### YES

- Proceed to step 5.

### 5. Is the TP Act LED illuminated?

#### NO

- Disconnect and reconnect the twisted pair cable to restart the initialization process.
- Restart the attached Powered Device to restart the initialization process.
- Contact Tech Support: 1-800-260-1312, Int'l: 00-1-952-941-7600.

#### YES

- Proceed to step 6.

### 6. Is the Fiber Link LED illuminated?

#### NO

- Check the fiber cables for proper connection.
- Verify that the TX and RX cables on the media converter are connected to the RX and TX ports, respectively, on the other device.
- Contact Tech Support: 1-800-260-1312, Int'l: 00-1-952-941-7600.

#### YES

- Proceed to step 7.

### 7. Is the Fiber Act LED illuminated?

#### NO

- Disconnect and reconnect the fiber cable to restart the initialization process.
- Restart the attached Powered Device to restart the initialization process.
- Contact Tech Support: 1-800-260-1312, Int'l: 00-1-952-941-7600.

#### YES

- Contact Tech Support: 1-800-260-1312, Int'l: 00-1-952-941-7600.

## Contact Us

### Technical Support

Technical support is available 24 hours a day.

US and Canada: **1-800-260-1312**

International: **00-1-952-941-7600**

### Transition Now

Chat live via the Web with Transition Networks Technical Support.

Log onto **www.transition.com** and click the **Transition Now** link.

### Web-Based Seminars

Transition Networks provides seminars via live web-based training.

Log onto **www.transition.com** and click the **Learning Center** link.

### E-Mail

Ask a question anytime by sending an e-mail to our technical support staff.

**techsupport@transition.com**

### Address

Transition Networks



6475 City West Parkway

Minneapolis, MN 55344, USA

telephone: 952-941-7600

toll free: 800-526-9267

fax: 952-941-2322

		<b>Declaration of Conformity</b>
Name of Mfg:	<b>Transition Networks</b> 6475 City West Parkway, Minneapolis MN 55344 USA	
Model:	<b>SEPOE10xx-150 Series Media Converters</b>	
Part Number(s):	<b>SEPOE1011-150, SEPOE1012-150, SEPOE1013-150, SEPOE1014-150</b>	
Regulation:	<b>EMC Directive 89/336/EEC</b>	
Purpose: To declare that the <b>SEPOE10xx-150</b> to which this declaration refers is in conformity with the following standards.		
EN 55024:1998; EN 61000-3-2:2000; EN 61000-3-3:1995+A1:2001, 21CFR subpart J		
<i>I, the undersigned, hereby declare that the equipment specified above conforms to the above Directive(s) and Standard(s).</i>		
 Stephen Anderson, Vice-President of Engineering		March 7, 2003 Date

---

# Compliance Information

EN55024



**CAUTION: RJ connectors are NOT INTENDED FOR CONNECTION TO THE PUBLIC TELEPHONE NETWORK. Failure to observe this caution could result in damage to the public telephone network.**

Der Anschluss dieses Gerätes an ein öffentliches Telekommunikationsnetz in den EG-Mitgliedstaaten verstösst gegen die jeweiligen einzelstaatlichen Gesetze zur Anwendung der Richtlinie 91/263/EWG zur Angleichung der Rechtsvorschriften der Mitgliedstaaten über Telekommunikationsendeinrichtungen einschliesslich der gegenseitigen Anerkennung ihrer Konformität.

## Trademark Notice

All registered trademarks and trademarks are the property of their respective owners.

## Copyright Restrictions

© 2004 Transition Networks.

All rights reserved. No part of this work may be reproduced or used in any form or by any means - graphic, electronic, or mechanical - without written permission from Transition Networks.

Printed in the U.S.A.

**33296.A**

---