

Transition Networks
CPSMC19xx-100
19-Slot *PointSystem*™ Chassis

User's Guide
(revision C)

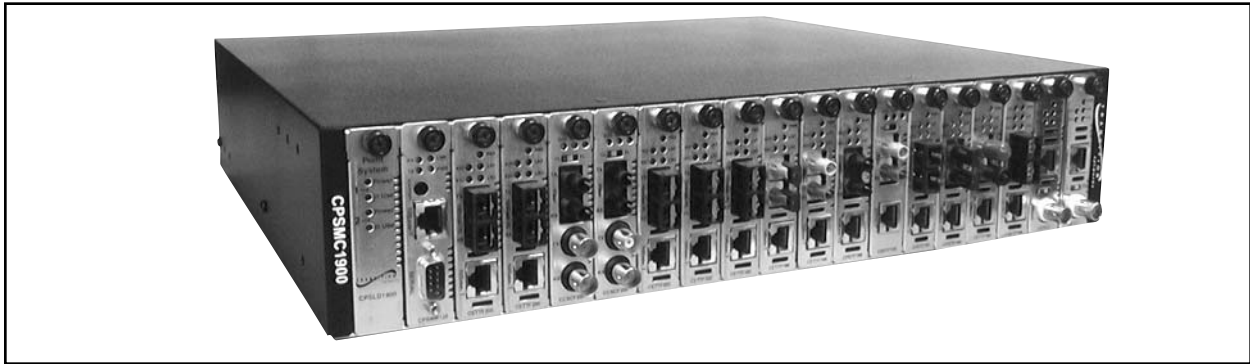

CPSMC1900-100

CPSMC1910-100

Compliance Information

UL Listed

C-UL Listed (Canada)

CISPR22/EN55022 Class A + EN55024

CE Mark

FCC Regulations

This equipment has been tested and found to comply with the limits for a Class A digital device, pursuant to part 15 of the FCC rules. These limits are designed to provide reasonable protection against harmful interference when the equipment is operated in a commercial environment. This equipment generates, uses, and can radiate radio frequency energy and, if not installed and used in accordance with the instruction manual, may cause harmful interference to radio communications. Operation of this equipment in a residential area is likely to cause harmful interference, in which case the user will be required to correct the interference at the user's own expense.

Canadian Regulations

This digital apparatus does not exceed the Class A limits for radio noise for digital apparatus set out on the radio interference regulations of the Canadian Department of Communications.

Le présent appareil numérique n'émet pas de bruits radioélectriques dépassant les limites applicables aux appareils numériques de la Class A prescrites dans le Règlement sur le brouillage radioélectrique édicté par le ministère des Communications du Canada.

European Regulations

Warning

This is a Class A product. In a domestic environment this product may cause radio interference in which case the user may be required to take adequate measures.

Achtung !

Dieses ist ein Gerät der Funkstörgrenzwertklasse A. In Wohnbereichen können bei Betrieb dieses Gerätes Rundfunkstörungen auftreten. In diesem Fall ist der Benutzer für Gegenmaßnahmen verantwortlich.

Attention !

Ceci est un produit de Classe A. Dans un environnement domestique, ce produit risque de créer des interférences radioélectriques, il appartiendra alors à l'utilisateur de prendre les mesures spécifiques appropriées



CAUTION: THE RJ CONNECTORS ON THE INDIVIDUAL MEDIA CONVERTER SLIDE-IN-MODULES ARE NOT INTENDED FOR CONNECTION TO THE PUBLIC TELEPHONE NETWORK. Failure to observe this caution could result in damage to the public telephone network.

Der Anschluss dieses Gerätes an ein öffentliches Telekommunikationsnetz in den EG-Mitgliedstaaten verstößt gegen die jeweiligen einzelstaatlichen Gesetze zur Anwendung der Richtlinie 91/263/EWG zur Angleichung der Rechtsvorschriften der Mitgliedstaaten über Telekommunikationsendeinrichtungen einschliesslich der gegenseitigen Anerkennung ihrer Konformität.

Trademark Notice

All trademarks and registered trademarks are the property of their respective owners.

Copyright Restrictions

© 2001-2004 Transition Networks.

All rights reserved. No part of this work may be reproduced or used in any form or by any means – graphic, electronic, or mechanical – without written permission from Transition Networks.

Printed in the U.S.A.

33242.C

Table of Contents

1	Introduction	.5
1.1	Description	.5
1.2	Unpacking the CPSMC19xx-100 Equipment	.6
2	Slide-in-Modules	.7
2.1	Media Converter Slide-in-Modules	.7
2.1.1	Chassis Face Plates	.7
2.1.2	Calculating the Power Consumption	.7
2.1.3	Installing the Media Converter Slide-in-Modules	.8
2.1.4	Replacing the Media Converter Slide-in-Modules	.9
2.2	Management Modules	.10
2.2.1	Three Types of Management Modules	.10
2.2.2	Installing the Management Modules	.11
2.2.3	Replacing the Management Modules	.12
2.3	Optional LED Slide-in-Module	.13
3	Powering the CPSMC19xx-100	.14
3.1	AC Power Supply Module	.14
3.2	DC Power Supply Module	.16
3.3	Optional Dual Power Supply Modules	.18
3.4	Power Supply Module Maintenance	.19
3.4.1	Primary/Secondary-Management/Manual Switch	.19
3.4.2	Installing the Power Supply Module	.20
3.4.3	Replacing the Power Supply Module	.21
3.4.4	Replacing the Power Supply Fuses	.22
3.5	Optional Fan Module	.24
4	CPSMC19xx-100 Chassis	.25
4.1	Installing the CPSMC19xx-100 Chassis	.25
4.1.1	Table Top Installation	.25
4.1.2	Standard 19-inch Rack Installation	.25
4.1.3	Grounding Lugs	.26
4.2	Cascade Option	.27
4.3	Connecting the Slide-in-Modules to the Network	.30
4.4	Operation	.30
5	Network Management	.31

6 Troubleshooting33

 Technical Specifications34

 Cable Specifications35

 Contact Us37

 Warranty38

1 Introduction

1.1 Description

The Transition Networks CPSMC19xx-100 19-Slot *PointSystem*™ chassis is a 19-inch, rack-mountable chassis for selected Transition Networks media converter slide-in-modules. The CPSMC19xx-100 allows the network administrator to connect various copper and fiber-optic network media over protocols that include Ethernet, Fast Ethernet, DS3/E3, and OC-12 and many others. The CPSMC19xx-100 provides installation space for up to 19 single-slot media converter slide-in-modules in the front of the unit.

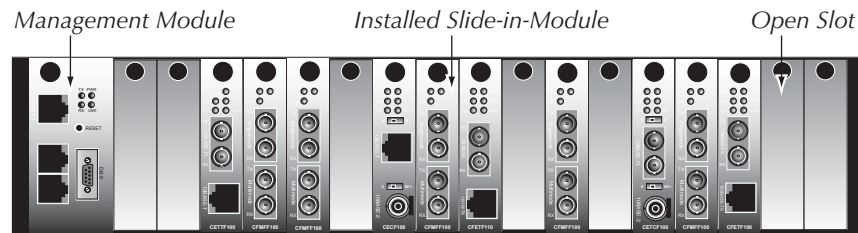

With an installed *PointSystem*™ **management module** (P/N CPSMM-120 or -200), the CPSMC19xx-100 can be managed and monitored via:

- An SNMP application such as Transition Networks *FocalPoint*™ management software installed at a remote Network Management Station (NMS).
- A remote Web browser.
- A command-line interface (CLI) at an attached terminal.
- A command-line-interface (CLI) at a remote Telnet connection.

The management modules also make it possible to control up to eight (8) cascaded CPSMC19xx-100 chassis fully populated with media converter slide-in-modules.

The CPSMC19xx-100 is equipped with an AC or DC Power Supply installed in the back of the chassis. An extra installation space is available for an optional redundant power supply (AC or DC) or an optional fan module.

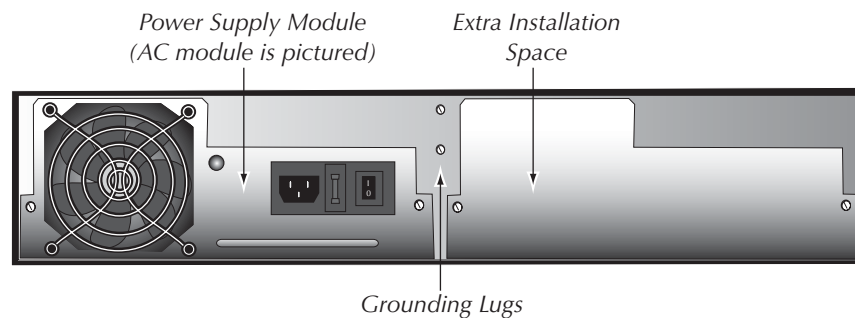

Finally, the CPSMC19xx-100 also comes equipped with a pair of grounding lugs for providing proper grounding of the chassis.

1.2 Unpacking the CPSMC19xx-100 Equipment

Use the following list to verify the shipment:

Item	Part Number
19-Slot chassis with AC Power Supply	CPSMC1900-100
19-Slot chassis with DC Power Supply	CPSMC1910-100
PointSystem™ Chassis Face Plates (19)	CPSFP-200
Power Cord	(varies by country)
User's Guide	33242

The following items are optional accessories for the CPSMC19xx-100 19-Slot PointSystem™ chassis:

Item	Part Number
Redundant AC Power Supply Module	CPSMP-200 (optional)
Redundant 48-VDC Power Supply Module	CPSMP-210 (optional)
Redundant Fan Module	CPSFM-200 (optional)
LED Slide-in-Module	CPSLD-100
Single-Slot Master Management Module	CPSMM-120 (optional)
Dual-Slot Master Management Module	CPSMM-200 (optional)
FocalPoint™ Software Disk (included with the management modules)	A1-7227
Expansion Management Module	CPSMM-210 (optional)
Management Module Cascade Connector	6026 (optional)
Rack Mount Ears	CPSRE-230 (optional)
Selectable media converter slide-in-module(s)	(various P/N) - (optional)

2 Slide-in-Modules

2.1 Media Converter Slide-in-Modules

Transition Networks media converter slide-in-modules, installed in slots at the front of the chassis, allow the network administrator to connect various copper and fiber-optic network media over protocols that include Ethernet, Fast Ethernet, DS3/E3, and OC-12 as well as many others (see www.transition.com for a complete listing.)

NOTE: Refer to the user's guide that comes with each media converter slide-in-module for cable, connector, and LED indicator information specific to that media converter slide-in-module.

2.1.1 Chassis Face Plates

CAUTION: Slots in the CPSMC19xx-100 chassis without a slide-in-module installed **MUST** have a protective chassis face plate (P/N CPSFP-200) covering the empty slot for Class A compliance.

Install a chassis face plate over any unused chassis slot by aligning the hole in the face plate with the threaded hole in the chassis. Secure the face plate with the enclosed bolt.

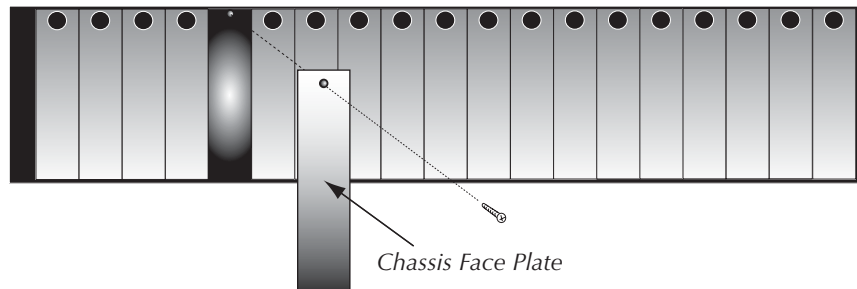

2.1.2 Calculating the Power Consumption

CAUTION: Before installing the media converter slide-in-modules, refer to the power consumption data for each individual media converter (provided in the user's guide shipped with each media converter). **The combined power consumption of all devices must not exceed the available power supply.** Failure to observe this caution could result in diminishing system reliability.

In other words, the combined power requirements of the CPSMC19xx-100 chassis **plus** all slide-in-modules must be **less than** the available power.

Contact Transition Networks Tech Support to ensure the power requirements for your specific application do not exceed the available power.

2.1.3 Installing the Media Converter Slide-in-Modules

CAUTION: Wear a grounding device and observe electrostatic discharge precautions when installing the media converter slide-in-module(s) into the chassis. **Failure to observe this caution could result in damage to, and subsequent failure of, the media converter slide-in-module(s).**

NOTE: The media converter slide-in-modules can be installed in any installation slot, in any order.

To install the media converter slide-in-module into the CPSMC19xx-100 chassis:

1. If a chassis face plate is covering the installation slot, remove the face plate from the installation slot by removing the one (1) screw that secures the plate to the front of the chassis.

NOTE: If the slide-in-module requires two slots, remove the face plates from two (2) adjacent installation slots.

2. Align the slide-in-module with the chassis installation slot so that the panel fastener screw is at the top of the module.

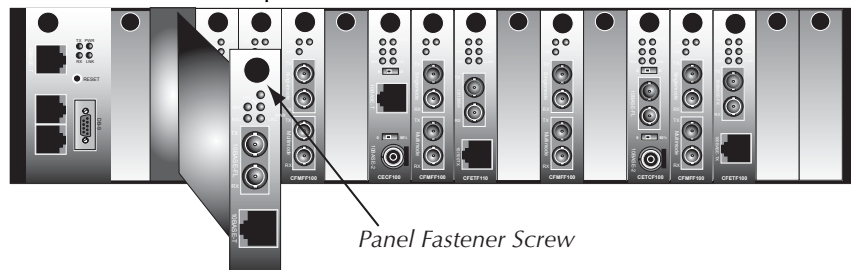

3. Carefully slide the slide-in-module into the installation slot, while aligning the module's circuit board with the installation guides.

NOTE: Ensure that the slide-in-module is firmly seated inside the chassis.

4. Push in and rotate the attached panel fastener screw clockwise to secure the module to the chassis.
5. Repeat steps 1 through 4 for any additional media converter slide-in-module(s).

2.1.4 Replacing the Media Converter Slide-in-Modules

CAUTION: Wear a grounding device and observe electrostatic discharge precautions when replacing media converter slide-in-module(s). **Failure to observe this caution could result in damage to, and subsequent failure of, the media converter slide-in-module(s).**

NOTE: The media converter slide-in-modules can be hot-swapped.

To replace a media converter slide-in-module in the CPSMC19xx-100 chassis:

1. Remove the slide-in-module to be replaced by loosening the panel fastener screw that secures the module to the chassis front. Slide the module from the chassis.

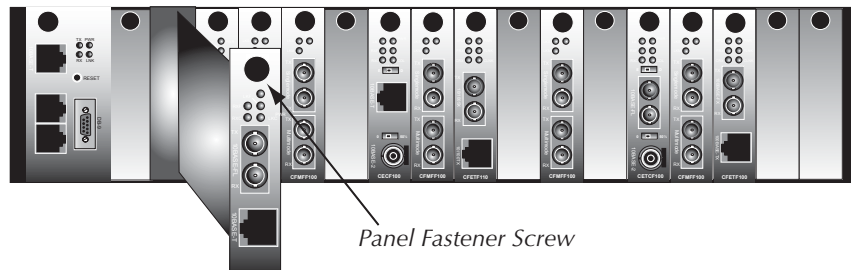

2. Align the replacement slide-in-module with the chassis installation slot so that the panel fastener screw is at the top.
3. Carefully slide the replacement slide-in-module into the installation slot, while aligning the module's circuit board with the installation guides.

NOTE: Ensure that the slide-in-module is firmly seated inside the chassis.

4. Push in and rotate the attached panel fastener screw clockwise to secure the module to the chassis.

2.2 Management Modules

Optional network management is provided by SNMP software embedded in Transition Networks *PointSystem*™ management module(s) that can be installed in the CPSMC19xx-100 chassis.

Transition Networks provides two such modules:

- CPSMM-120 Single-Slot Master Management Module.
- CPSMM-200 Dual-Slot Master Management Module.

Along with an additional expansion module:

- CPSMM-210 Single Slot Expansion Management Module.

2.2.1 Three Types of Management Modules

CPSMM-120 Single-Slot Master Management Module

The optional CPSMM-120 Single-Slot Master Management Module can be installed to enable network management of a single CPSMC19xx-100 chassis.

Refer to the CPSMM-120 user's guide for more information on the CPSMM-120 Single-Slot Master Management Module.

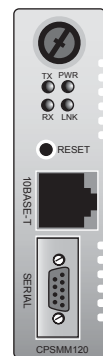

CPSMM-200 Dual-Slot Master Management Module

The optional CPSMM-200 Dual-Slot Master Management Module can also be installed in the CPSMC19xx-100 chassis to enable network management.

This module has all of the features of the CPSMM-120 plus a pair of cascade ports, which allow multiple *PointSystem*™ chassis to be connected.

Note also that this module requires **two** adjacent slots in the CPSMC19xx-100 chassis for installation.

Refer to the CPSMM-200/-210 user's guide for more information on the CPSMM-200 Dual-Slot Master Management Module.

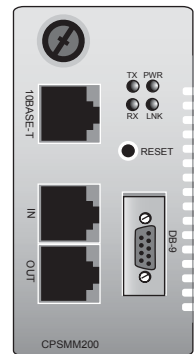

CPSMM-210 Single-Slot Expansion Management Module

The CPSMM-210 is used with the CPSMM-200 to connect up to eight (8) *PointSystem*™ chassis into one manageable stack.

Refer to the CPSMM-200/-210 user's guide for more information on the CPSMM-210 Single-Slot Expansion Management Module.

NOTE: See section 4.3 *Cascade Option* for details on connecting multiple CPSMC19xx-100 chassis.

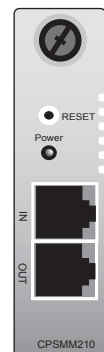

2.2.2 Installing the Management Modules

CAUTION: Wear a grounding device and observe electrostatic discharge precautions when installing the management module into the CPSMC19xx-100 chassis. **Failure to observe this caution could result in damage to, and subsequent failure of, the management module.**

NOTE: Transition Networks recommends installing the management module into the left-most installation slot to keep the management module cables separate from the media converter cables.

To install a management module into the CPSMC19xx-100 chassis:

- 1a. **CPSMM-200 Dual-Slot Master Management Module:** If chassis face plates are covering the installation slots, remove the face plates from the two (2) installation slots at the far-left position of the chassis.

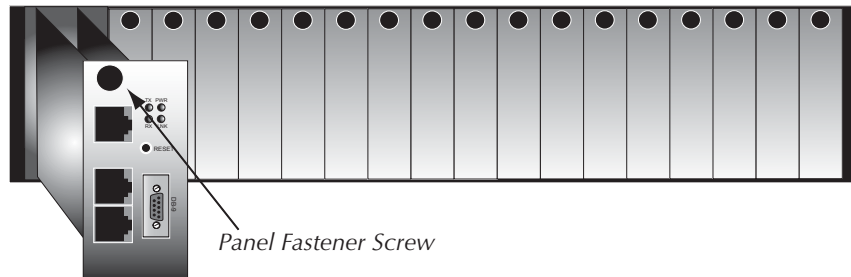

- 1b. **CPSMM-120 Single-Slot Master Management Module OR CPSMM-210 Single-Slot Expansion Management Module:** If chassis face plates are covering the installation slots, remove the face plate from the one (1) installation slot at the far-left position of the chassis.

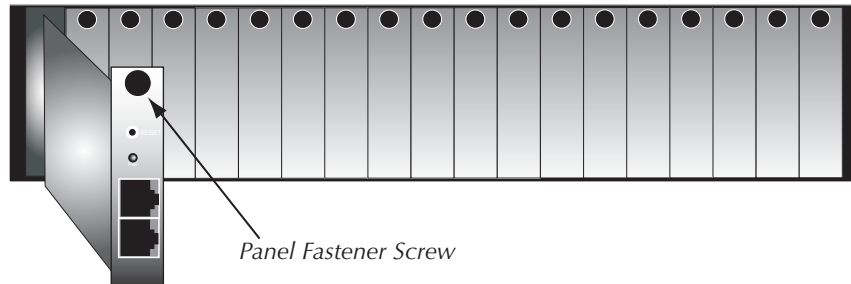

2. Align the management module with the chassis installation slot so that the panel fastener screw is at the top of the module.
3. Carefully slide the management module into the installation slot, while aligning the module's circuit board with the installation guides.

NOTE: Ensure that management module is firmly seated inside the chassis.

4. Push in and rotate the attached panel fastener screw clockwise to secure the management module to the chassis.

2.2.3 Replacing the Management Modules

CAUTION: Wear a grounding device and observe electrostatic discharge precautions when replacing the media converter slide-in-module(s). **Failure to observe this caution could result in damage to, and subsequent failure of, the management module(s).**

NOTE: The management modules can be replaced while the chassis remains powered. However, **you must configure a new IP address for the replacement management module.** For more information, see the *FocalPoint™ 2.0* user's guide on the enclosed application CD or on-line at www.transition.com.

To replace a management module in the CPSMC19xx-100 chassis:

1. Remove the management module to be replaced by loosening the panel fastener screw that secures the module to the chassis front. Slide the module from the chassis.
2. Align the replacement Management module with the installation slot so that the panel fastener screw is at the top.

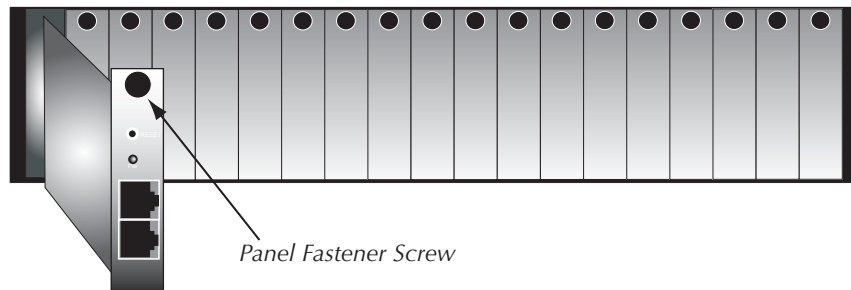

3. Carefully slide the replacement management module into the installation slot, while aligning the module's circuit board with the installation guides.

NOTE: Ensure that the management module is firmly seated inside the chassis.

4. Push in and rotate the attached panel fastener screw clockwise to secure the module to the chassis.

2.3 Optional LED Slide-in-Module

The optional LED slide-in-module (CPSLD-100) allows the network administrator to determine at a glance which power supplies are installed and in use.

The LED module can be installed in any slot in the front of the chassis. The procedure to install and replace it is the same as any other slide-in-module. (See sections 2.1.3 *Installing the Media Converter Slide-in-Modules* and section 2.1.4 *Replacing the Media Converter Slide-in-Modules* for more information.)

When the chassis is powered on, the installed LED slide-in-module goes through a self-test where the four LEDs will light up in sequence. After the self-test, the LEDs indicate the current power supply operating conditions.

Power and **In Use** LED indicators are provided for each installed power supply Modules (see the figure to the right).

The numerical designation on the LED slide-in-modules is as follows:

- 1 Refers to the power supply installed in the **left** installation slot (when looking at the chassis from the rear).
- 2 Refers to the power supply installed in the **right** installation slot (when looking at the chassis from the rear).

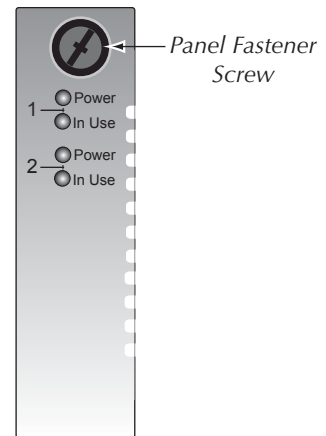

See chapter 3 *Powering the CPSMC19xx-100* for more information on the power supply for the CPSMC19xx-100 chassis.

3 Powering the CPSMC19xx-100

3.1 AC Power Supply Module

The **CPSMC1900-100 PointSystem™** chassis is equipped with an AC power supply module (P/N **CPSMP-200**) installed in the back of the chassis. The power supply module supplies power to the chassis, installed media converter slide-in-modules, management modules, and the optional fan module.

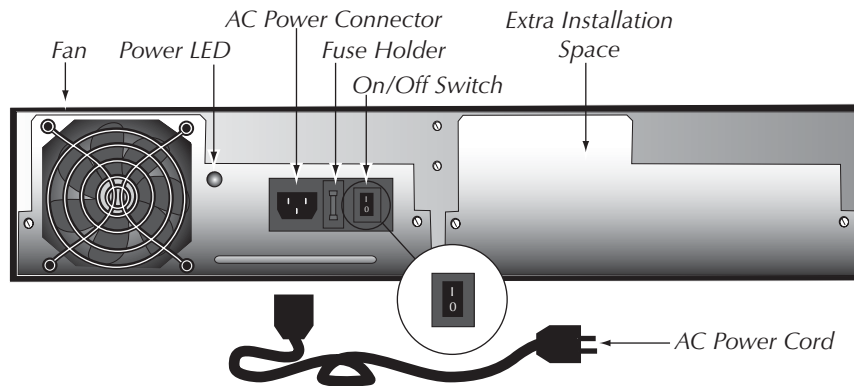

The components of the AC power supply module include:

- An **AC power cord** that distributes power from an external outlet to an **AC power connector** on the power supply module.
- An **On/Off switch** that, when set to “**I**”, allows the module to supply power to the chassis and any installed modules.
- A **power LED** indicator.
- A **fan** to prevent the power supply module from overheating.
- An **fuse** installed in a fuse holder.

Optional Redundant AC Power Supply Module

An extra installation space is available in the back of the chassis for installing an optional redundant AC power supply module (P/N **CPSMP-200**).

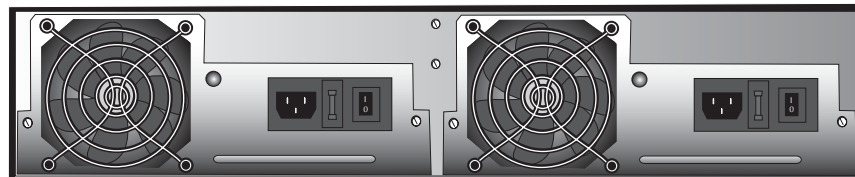

See section 3.4 *Power Supply Module Maintenance* for instructions on installation.

Powering the AC Power Supply Module

To power the **CPSMC1900-100 PointSystem™** chassis through the AC power supply module:

1. Set the On/Off switch to “0”.
2. Connect female end of the power cord to the AC power connector on the power supply module.
3. Plug the male end of the power cord into the correct voltage AC rack or wall socket.
4. Set the On/Off switch to “1”.
5. Verify that the chassis is powered by observing the illuminated power LED and fan operation.

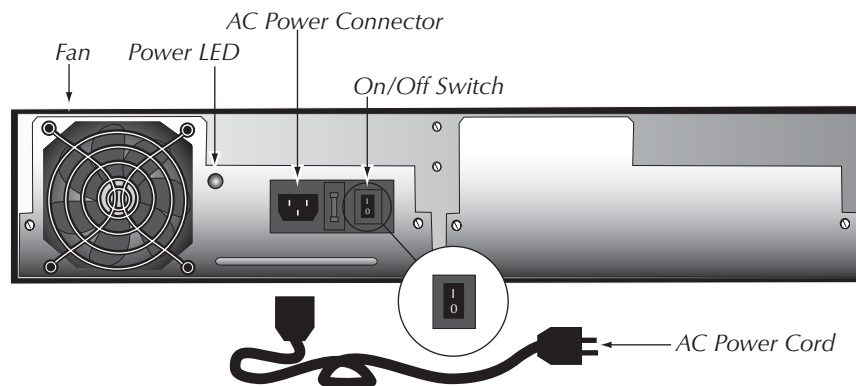

3.2 DC Power Supply Module

The **CPSMC1910-100 PointSystem™** chassis is equipped with a DC power supply module (P/N **CPSMP-210**) installed in the back of the chassis. The power supply module supplies power to the chassis, installed media converter slide-in-modules, management modules, and the optional fan module.

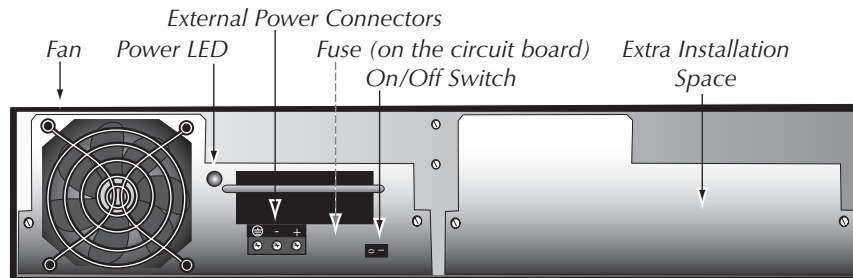

The components of the DC power supply module include:

- A set of three (3) **external power connectors** that distribute power from an external 48-VDC outlet to a chassis ground connector, a positive (+) connector, and a negative (-) connector on the DC power supply module.
- An **On/Off switch** that, when set to “I”, allows the module to supply power to the chassis, and any installed modules.
- A **power LED** indicator.
- A **fan** to prevent the power supply module from overheating.
- A **fuse** installed on the power supply module’s circuit board.

power supply

Optional Redundant DC Power Supply Module

An extra installation space is available in the back of the chassis for installing an optional redundant DC power supply module (P/N **CPSMP-210**).

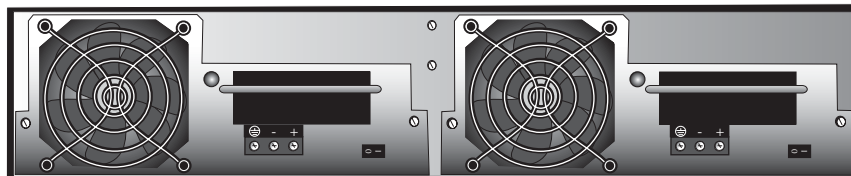

See section 3.4 *Power Supply Module Maintenance* for instructions on installation.

Read and follow all warning notices & instructions marked on the product or included in the manual.

CAUTION: All installation and service must be performed by qualified service personnel.

CAUTION: Ensure that the external power source is **NOT** powered and that the On/Off switch is set to “0” when connecting the 48-VDC power supply module. Failure to observe this caution could result in damage to, and subsequent failure of, the 48-VDC power supply module.

Powering the DC Power Supply Module

- This product is intended to be used in a restricted access location. Proper earthing (grounding) is required to ensure safe operation. Grounding terminals are provided (section 4.1.3) for proper grounding of the device as per customer installation requirements and local electrical codes. Prior to installation, use a voltmeter/ohmmeter to check the wiring for the presence of earth ground.
- A readily accessible disconnect device as part of the building installation shall be incorporated into the fixed wiring. The disconnect device (a 48 VDC, 15 or 20A circuit breaker or switch) must be included in the ungrounded supply conductor. Overcurrent protection must be a 48 VDC, 15 or 20A fuse or circuit breaker.

To power the **CPSMC1910-100** chassis through the DC power supply module:

1. Set the On/Off switch to “0”.
2. Verify that the external power source is **NOT** powered.

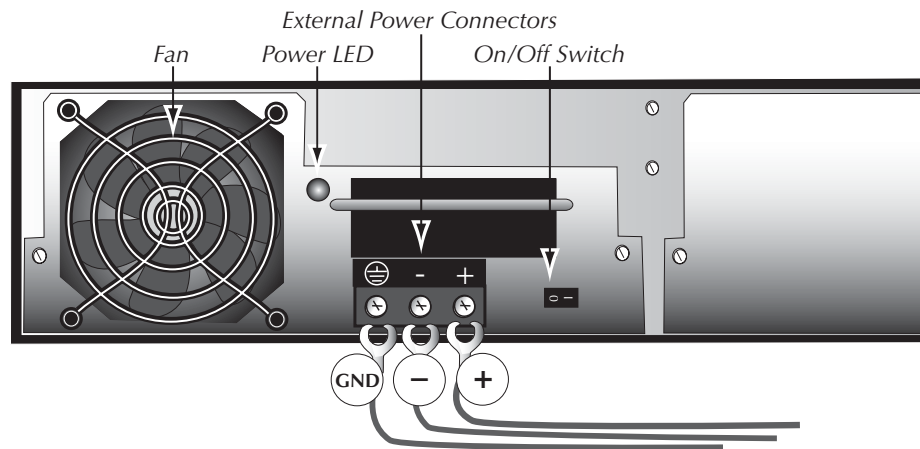

3. Connect the +48-VDC terminal to the chassis external power connector marked “+”. Turn the terminal screw clockwise to secure.
4. Connect the -48-VDC terminal to the chassis external power connector marked “-”. Turn the terminal screw clockwise to secure.
5. Connect the ground terminal to the chassis external power connector marked “chassis ground”. Turn the terminal screw clockwise to secure.
6. Power up the external power source.
7. Set the DC power supply module power switch to “I”.
8. Verify that chassis is powered by observing the illuminated power LED and fan operation.

3.3 Optional Dual Power Supply Modules

Alternatively, both an AC power supply module and a DC power supply module can be installed in the same chassis.

NOTE: The drawing below shows the AC module in the left installation slot and the DC module in the right. However, either power supply module can be installed in either installation space.

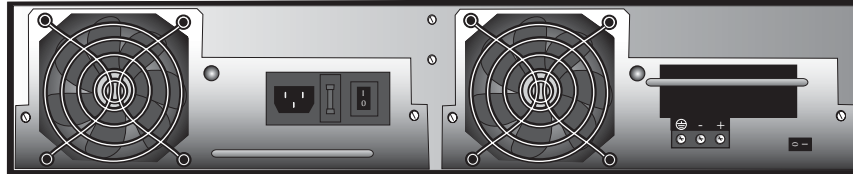

See section 3.4 *Power Supply Module Maintenance* for instructions on installation.

3.4 Power Supply Module Maintenance

3.4.1 Primary/Secondary-Management/Manual Switch

Both the AC (CPSMP-200) and DC (CPSMP-210) power supply modules have a set of *Primary/Secondary-Management/Manual* switches installed on the circuit board.

Management/Manual Switch

The Management/Manual switch allows the *PointSystem*™ software to control and override the physical setting on the Primary/Secondary switch.

- When set to **'Management'**, the power supply module has the default setting of 'Primary' unless changed, at the software interface, to 'Secondary'.
- When set to **'Manual'**, the power supply module is set by the Primary/Secondary switch. The software interface cannot change the setting.

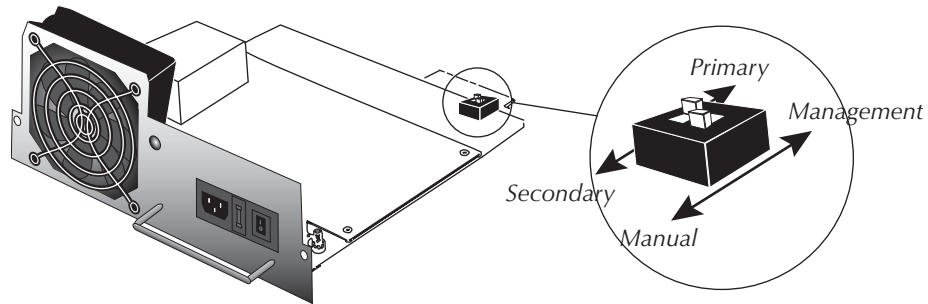

power supply

Primary/Secondary Switch

The Primary/Secondary switch allows the power supply module to be configured as the 'Primary' or as the 'Secondary' power supply module.

- As the **'Primary'** power supply, it provides power to the entire chassis.
- As the **'Secondary'** power supply, it waits in stand-by, ready to supply power to the chassis in the event of power failure from the 'Primary' power supply.

Configuring Two Power Supply Modules

- For **load sharing**, where each module supplies power to half the chassis, set both power supply modules to 'Primary'.
- For **back-up power supply**, set one power supply module to 'Primary' (which supplies power to the entire chassis) and the other to 'Secondary'. In this mode, the secondary module is in stand-by and takes over in the event of a power failure of the primary module.

NOTE: At least one power supply module **must** be set to 'Primary.' If both modules are set to 'Secondary,' neither will supply power to the chassis.

CAUTION: In a 0 - 60°C (32 - 140°F) environment, two power supplies must be installed and both must be configured for load sharing.

WARNING: Do NOT connect the power supply module to the external power before installing it into the chassis. Failure to observe this caution could result in equipment damage and/or personal injury or death.

3.4.2 Installing the Power Supply Module

The AC and DC modules are installed in the same manner.

NOTE: At least one power supply module **must** be set to 'Primary.' If both modules are set to 'Secondary,' neither will supply power to the chassis.

1. Remove the power supply module protective plate from the installation slot by removing and retaining the two (2) screws that secure the plate to the chassis.

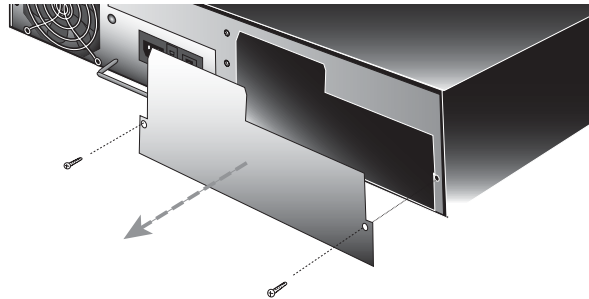

2. Set the **Primary/Secondary** switch and the **Management/Manual** switch, if necessary. (See section 3.4.1)
3. Carefully slide the power supply module into the installation slot, aligning the power supply module with the installation guides. Ensure that the power supply module is firmly seated inside the chassis.

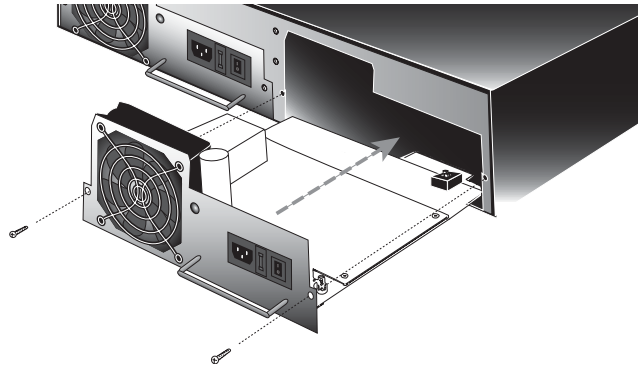

4. Carefully install the two (2) screws (retained in Step 1) through the power supply module into the chassis, rotating clockwise to secure.
5. Connect the power supply module to the external power supply (AC: see page 15; DC: see page 17).

power supply

WARNING: Do NOT connect the Power Supply Module to the external power before installing it into the chassis. Failure to observe this caution could result in equipment damage and/or personal injury or death.

3.4.3 Replacing the Power Supply Module

The AC and DC modules are replaced in the same manner.

Both the AC (CPSMP-200) and DC (CPSMP-210) power supply modules may be hot swapped **provided the module to be swapped has been disconnected from the external power source and the On/Off switch has been set to “0”**.

NOTE: At least one power supply module **must** be set to ‘Primary.’ If both modules are set to ‘Secondary,’ neither will supply power to the chassis.

1. Set the power supply module power switch to “0”.
2. **Disconnect the power supply module from the external power source.**
3. Remove the two (2) screws that secure power supply module to the chassis. Retain the screws for installing the replacement power supply module.
4. Slide the power supply module from the chassis.
5. Set the **Primary/Secondary** switch and the **Management/Manual** switch on the replacement power supply module, if necessary. (See section 3.4.1)
6. Carefully slide the replacement power supply module into the installation slot, aligning the module with the installation guides. Ensure that the the module is firmly seated inside the chassis.

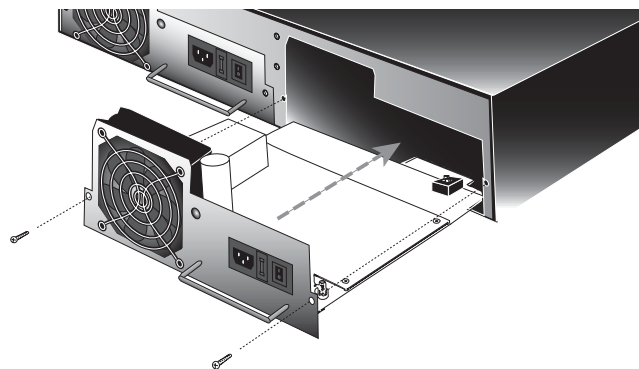

7. Carefully install the two (2) retained screws through the power supply module into the chassis, rotating clockwise to secure.
8. Connect the power supply module to the external power source. (AC: see page 15 / DC: see page 17.)

WARNING: Do NOT connect the power supply module to the external power before installing it into the chassis. Failure to observe this caution could result in equipment damage and/or personal injury or death.

3.4.3 Replacing the Power Supply Fuses

Replacing the AC Fuse

CAUTION: Wear a grounding device and observe electrostatic discharge precautions when replacing the fuse in the power supply module. Failure to observe this caution could result in damage to, and subsequent failure of, the power supply module.

NOTE: Replace the fuse only with the same size and rating. Failure to observe this caution could result in equipment damage.

1. Set the AC power supply module power switch to "0".
2. **Disconnect the power supply module from the external power source.**
3. From the inside edge of the power receptacle, insert a small flat blade screwdriver into the groove on the front, inside edge of the fuse holder and carefully pry the fuse holder from the power supply module.

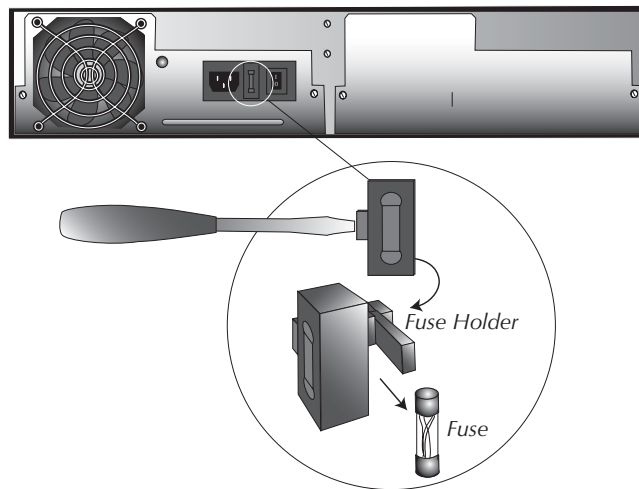

4. Carefully remove the fuse from the fuse holder.
5. Install a **same size and rating** replacement fuse in the fuse holder.
6. Return the fuse holder and fuse to the installation position in the power supply module. **Snap the fuse holder into place.**
7. Connect the power supply module to the external power source (see page 15).

WARNING: Do NOT connect the power supply module to the external power before installing it into the chassis. Failure to observe this caution could result in equipment damage and/or personal injury or death.

Replacing the DC Fuse

CAUTION: Wear a grounding device and observe electrostatic discharge precautions when replacing the fuse in the power supply module. Failure to observe this caution could result in damage to, and subsequent failure of, the power supply module.

NOTE: Replace the fuse only with the same size and rating. Failure to observe this caution could result in equipment damage.

1. Set the DC power supply module power switch to "0".
2. **Disconnect the power supply module from the external power source.**
3. Remove the power supply module by removing the two (2) screws that secure the module to the chassis. Slide the module from the chassis.
4. Remove the fuse from the fuse holder.

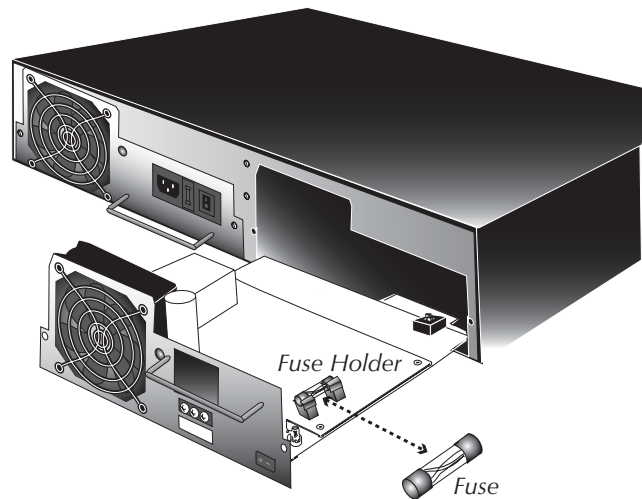

5. Install a **same size and rating** replacement fuse in the fuse holder.
6. Slide the power supply module into the installation slot, aligning the module with the installation guides. Ensure that the module is firmly seated inside the chassis.
7. Install the two (2) retained screws through the power supply module into the chassis, rotating clockwise to secure.
8. Connect the power supply module to the external power source (see page 17).

3.5 Optional Fan Module

The optional fan module (CPSFM-200) can be installed in the extra installation space in the back of the CPSMC19xx-100 chassis to provide additional cooling for the entire chassis.

CAUTION: Wear a grounding device and observe electrostatic discharge precautions when installing the fan module into the chassis. Failure to observe this caution could result in damage to, and subsequent failure of, the fan module.

NOTE: The fan module can be hot-swapped.

To install the fan module into the CPSMC19xx-100 chassis:

1. Remove the protective plate from the installation slot by removing and retaining the two (2) screws that secure the plate to the chassis.

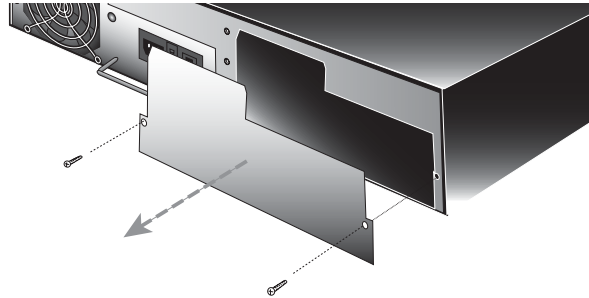

2. Carefully slide the fan module into the installation slot, aligning the module with the installation guides. Ensure the module is firmly seated inside the chassis.

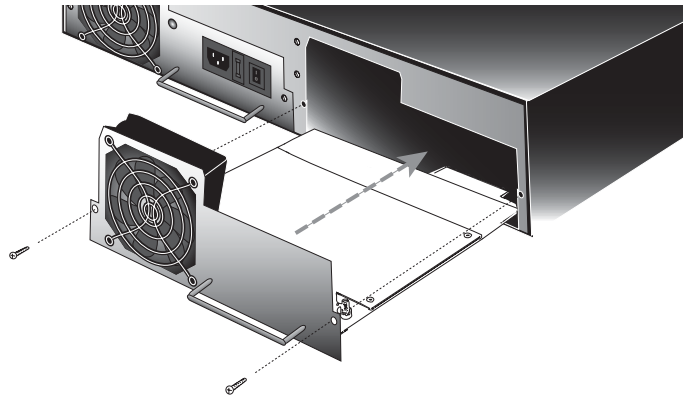

3. Carefully install the two (2) retained screws through the fan module into the chassis, rotating clockwise to secure.
4. Verify that the fan module is powered by observing the fan operation.

4 CPSMC19xx-100 Chassis

4.1 Installing the CPSMC19xx-100 Chassis

The CPSMC19xx-100 can be installed in a standard 19-inch rack or on a table, shelf, or other stable surface.

CAUTION: Install the chassis so that the air flow around it is not restricted.

4.1.1 Table-Top Installation

The CPSMC19xx-100 chassis is shipped with nine (9) rubber feet for optional installation on a table or other flat, stable surface in a well-ventilated area. If table-top installation is desired, remove the rubber feet from the card and place them on the bottom of the chassis. Distribute the feet so that the chassis is level when placed upright.

4.1.2 Standard 19-inch Rack Installation

The maximum recommended ambient temperature (T_{mra}) for the CPSMC19xx-100 chassis is **50°C**. (**60°C** when using load-sharing power supply modules) If the CPSMC19xx-100 chassis is installed in a closed or multi-unit rack assembly, **the operating ambient temperature of the the rack environment may be greater than room ambient.**

NOTE: Rack-mounted equipment must be reliably grounded. Power supply connections **other than direct connections** to the branch circuit (e.g., use of power strips) should be employed.

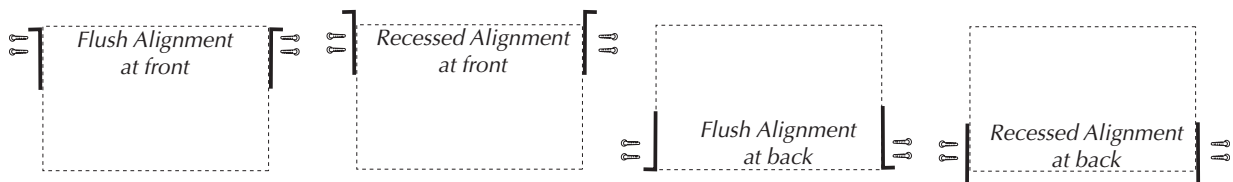

The CPSMC19xx-100 chassis is designed so that the installation brackets can be installed to align the chassis either **flush** against the front or back edge of the rack or **recessed** from the front or back edge of the rack.

WARNING: Select mounting bracket locations on the chassis that will keep the chassis balanced when mounted in the rack. Failure to observe this warning could allow the chassis to fall, resulting in equipment damage and/or possible injury to personnel.

To install the CPSMC19xx-100 chassis into a standard 19-inch rack:

1. Determine the preferred alignment of the chassis in the rack.

NOTE: Installation bracket mounting screws are provided. Rack mount screws and clip nuts are NOT provided.

2. Locate six (6) installation bracket mounting screws (provided) for each chassis to be installed.

WARNING: Mount the chassis evenly and securely onto the rack. Failure to observe this warning could allow the chassis to fall, resulting in equipment damage and/or possible injury to personnel.

3. Align the universal mounting bracket in the selected position against the side of the chassis so that the chassis installation holes are visible through the universal bracket installation holes.
4. Using a Phillips screwdriver, install the three (3) screws through the mounting bracket into the installation holes on side of the chassis.
5. Repeat steps 3 and 4 for the second mounting bracket.

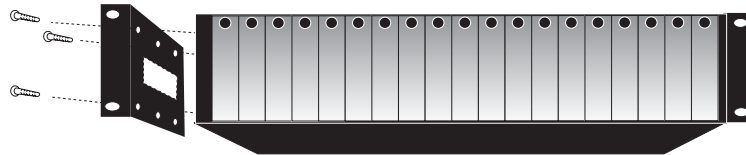

6. Locate four (4) screws (not provided) and optional clip-nuts (not provided) for each chassis to be installed.
7. Carefully align the chassis at a secure and level position between the 19-inch site rack mounting rails.
8. Install two (2) screws through the right bracket into the right mounting rail and two (2) screws through the left bracket into the left mounting rail, using the clip nuts to secure, if necessary.

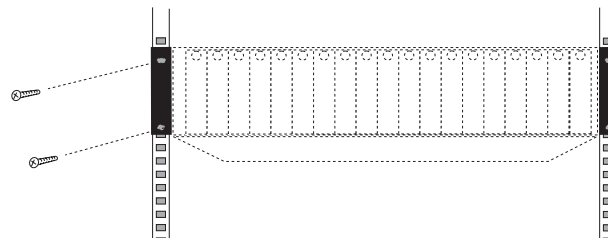

4.1.3 Grounding Lugs

The CPSMC19xx-100 comes equipped with grounding lugs, which are provided for a grounding conductor wire terminated with a **two-hole, compression-type, grounding connector**. The grounding wire -- which must be a copper conductor -- is not included with the chassis and must be provided by the customer/installer.

The electrical conducting path from the chassis must:

- Flow via the grounding lugs to the Common Bonding Network (CBN) for telecom installations; or to an alternate approved grounding system (if required) for non-telecom installations,
- Be of sufficiently low impedance to conduct fault currents likely to be imposed on the chassis, and
- Enable proper operation of any over-current protection devices.

The two-hole, compression-type, grounding connector **must be fastened to the grounding lugs with the enclosed, anti-rotation star-washers and lug-nut fasteners**. The required torque to the fasteners is specified by the connector's manufacturer.

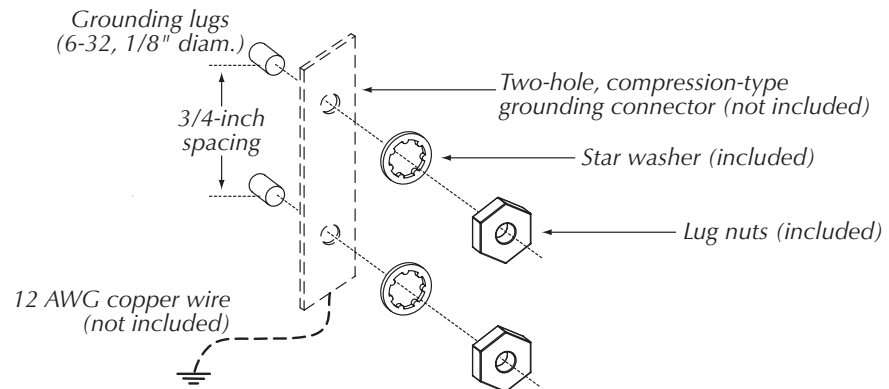

To properly ground the CPSMC19xx-100 chassis:

1. Obtain one (1) properly-terminated, grounding conductor (12 AWG copper wire gauge or larger) with a two-hole, compression-type, grounding connector. Note the manufacturer's applied torque that is required for the connector.
2. Attach the grounding conductor to the chassis by placing the two-hole, compression-type connector onto the grounding lugs and fasten with appropriate lock-washers and lug-nuts at the proper torque.
3. Attach the opposite end of the properly-terminated grounding conductor to the Common Bonding Network (CBN) for telecom installations, or to an approved grounding system (if required) for non-telecom installations.

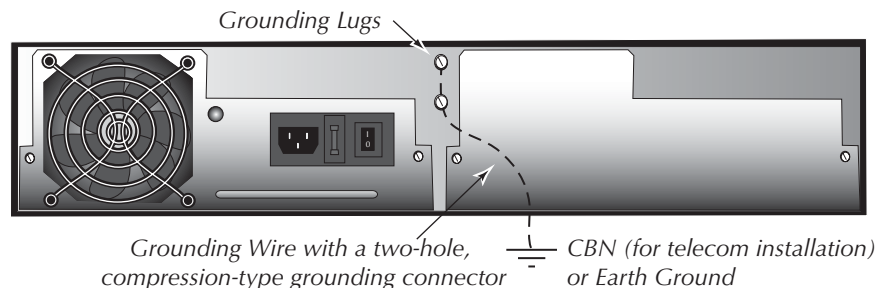

4.2 Cascade Option

The management module cascade option allows the network administrator to connect up to eight (8) CPSMC19xx-100 chassis into one manageable stack, providing a single management source for up to 143 conversion devices.

To create the cascade option, the CPSMM-200 Dual Slot Master Management Module is installed in the first chassis in the series. The CPSMM-210 Single-Slot Expansion management module is installed in each subsequent chassis.

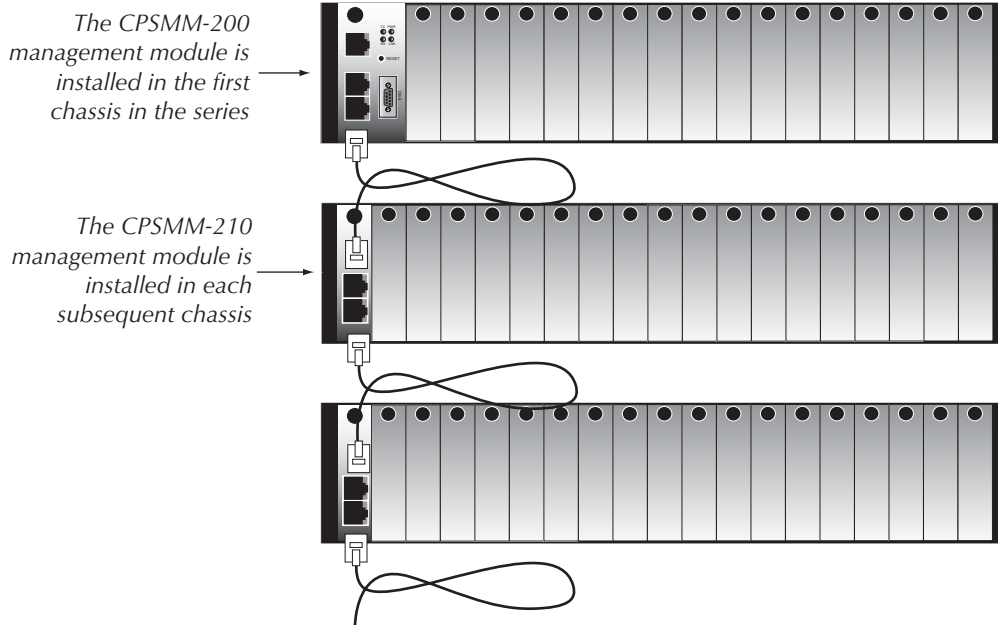

An alternative setup involves installing two CPSMM-200 Dual-Slot Master Management Modules into two adjacent chassis for redundant management.

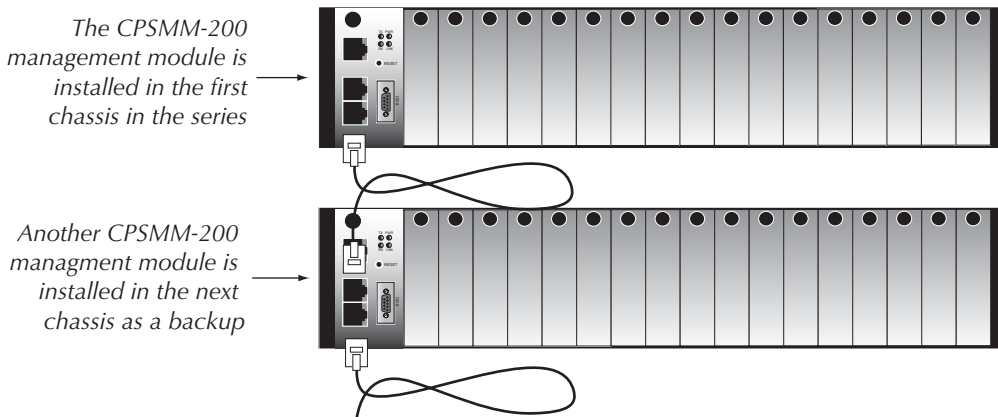

In this set-up, the two CPSMM-200 management modules auto-negotiate so that one is the primary module while the other is in stand-by mode. If the primary module fails, the stand-by module automatically takes over and manages the network.

chassis

Cascading multiple CPSMC19xx-100 chassis

To cascade two or more CPSMC19xx-100 chassis:

1. Locate one (1) Transition Networks management module cascade cable (with RJ-45 connectors installed at both ends) (P/N 6026) for each set of two (2) chassis to be cascaded.

NOTE: Transition Networks management module cascade cables are one (1) meter long. Ensure that the chassis are installed within one (1) meter of each other.

2. At the first chassis in the series: Plug the RJ-45 connector at one end of the cascade cable into the management module's RJ-45 port labeled "OUT".
3. At the next chassis in the series: Plug the RJ-45 connector at the other end of the cascade cable into the management module's RJ-45 port labeled "IN".
4. At the same chassis as in step 3: Plug the RJ-45 connector at one end of the cascade cable into the management module's RJ-45 port labeled "OUT".
5. At the next chassis in the series: Plug the RJ-45 connector at the other end of the cascade cable into the management module's RJ-45 port labeled "IN".
6. Repeat steps 4 and 5 until all chassis have been connected.

4.3 Connecting the Slide-in-Modules to the Network

Once the CPSMC19xx-100 chassis has been installed, the media converter slide-in-modules may be connected to the network.

CAUTION: Connect input/output network cables ONLY to media converter slide-in-module connectors within the same network protocol (such as Ethernet-to-Ethernet, Fast Ethernet-to-Fast Ethernet, ATM-to-ATM). Failure to observe this caution will cause data transfer to fail.

Refer to user's guides included with the media converter slide-in-modules for cabling specifications and instructions.

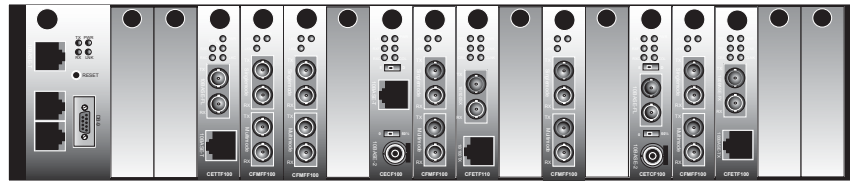

Check the individual user's guide for specific information on how to connect each slide-in-module to the network.

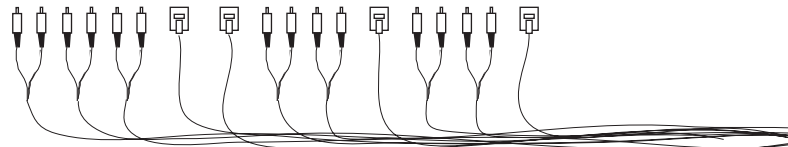

4.4 Operation

Daily operation of the CPSMC19xx-100 chassis requires no network administrator activity except for the occasional monitoring of the status LED indicators on the chassis and on the installed media converter slide-in-modules.

Each media converter slide-in-module and each management module has one or more LED indicators to help monitor the CPSMC19xx-100 chassis network.

Refer to the user's guide included with each management module and slide-in-module to interpret the LED indicators.

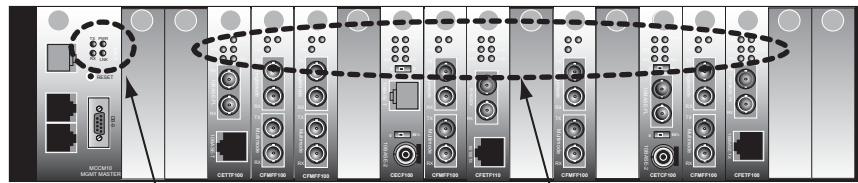

LED indicators on the management module and slide-in-modules

5 Network Management

The CPSMM100 firmware and the *FocalPoint*™ application are described in the ***FocalPoint*™ 2.0 Management Application and CPSMM100 Firmware** user's guide (P/N 33293). This manual is included on the application CD and is also available on-line at www.transition.com.

Transition Networks CPSMM100 firmware is embedded in the optional management modules (see section 2.2). The firmware allows the network administrator to configure and manage the CPSMC19xx-100 chassis from an attached terminal or from a remote, networked computer.

The firmware includes the Transition Networks **Command Line Interface (CLI)**, a **telnet server**, a **Web browser**, and an **SNMP** (Simple Network Management Protocol) agent.

In addition, Transition Networks ***FocalPoint*™ application** can be installed in the networked computer to provide a graphical user interface to monitor the *PointSystem*™ chassis.

Hardware Connections

Network management can be implemented either through the DB-9 serial port or through the RJ-45 Ethernet port of the management modules.

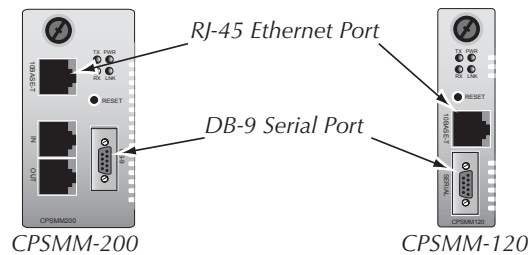

DB-9 Serial Port

The DB-9 serial port allows the network administrator to configure and manage the CPSMC19xx-100 chassis using the SNMP Command-Line Interface (CLI) at an attached terminal or terminal emulator.

Use a **null modem cable** to attach a terminal to the DB-9 serial port on the management module as shown.

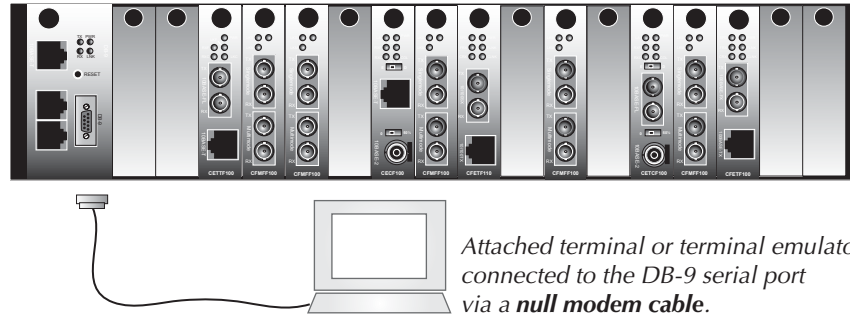

RJ-45 Ethernet Port

The RJ-45 Ethernet port allows the network administrator to manage the CPSMC19xx-100 chassis via a remote Network Management Station (NMS) in one of two ways:

1. Using the Transition Networks *FocalPoint*™ graphical user interface.
2. Using a remote Telnet connection.

Use an RJ-45 network cable to attach a terminal (via a network hub or switch) to the RJ-45 Ethernet port on the management module as shown.

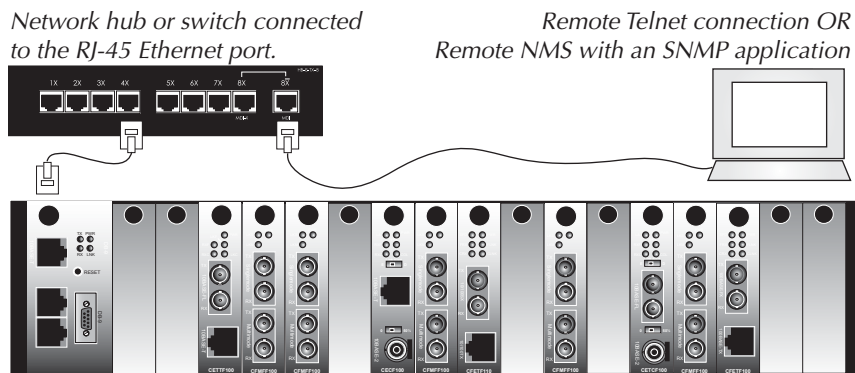

NOTE: To manage the *PointSystem*™ chassis via a remote NMS, both the RJ-45 Ethernet port and the NMS must be connected to a network with Internet access.

network mgmt.

6 Troubleshooting

1. **Are any of the power LEDs on any of the slide-in-modules illuminated, AND are the fans operating?**

YES

- The chassis is receiving power. Proceed to the next step.

NO

- Check all power supply cables for proper connection.
- For AC power: Ensure the AC receptacle on the wall is supplying power.
- If the fuse for the AC receptacle on the wall blows repeatedly, have the AC receptacle inspected by a qualified electrician.
- For DC power: Ensure the DC power supply is supplying power.
- Check the fans to see if they are operating.
- Contact Technical Support: U.S./Canada: 1-800-260-1312, International: 00-1-952-941-7600.

2. **For the management modules (CPSMM-120, CPSMM-200, CPSMM-210), are ANY of the power LEDs NOT illuminated?**

NO

- All management modules are receiving power. Proceed to the next step.

YES

For those management modules where the power LED is NOT illuminated:

- Ensure the management module is firmly seated in the slot.
- Press the RESET button on the management module.
- Contact Technical Support: U.S./Canada: 1-800-260-1312, International: 00-1-952-941-7600.

3. **For the remaining slide-in-modules, are ANY of the power LEDs NOT illuminated?**

NO

- All slide-in-modules are receiving power. Proceed to the next step.

YES

For those slide-in-modules where the power LED is NOT illuminated:

- Ensure the slide-in-module is firmly seated in the slot.
- Contact Technical Support: U.S./Canada: 1-800-260-1312, International: 00-1-952-941-7600.

4. **To determine if a fault is due to a software problem, consult the troubleshooting section of the *FocalPoint™ 2.0 Management Application and CPSMM100 Firmware User's Guide* (P/N 33293). This manual is available on the enclosed application CD and on-line at www.transition.com.**

5. **To determine if a fault is due to an individual management module or slide-in-module, consult the troubleshooting section of the user's guide for that particular module.**

6. **If none of the solutions listed in this section resolves the problem, contact Technical Support: U.S./Canada: 1-800-260-1312, International: 00-1-952-941-7600.**

Technical Specifications

For use with Transition Networks Model CPSMC19xx-100 or equivalent.

Dimensions 17 x 14.3 x 3.5 inches (430 x 363 x 89 mm)

Weight 17.5 lbs. (8.0 kg)

MTBF (Mean Time Before Failure)	MIL217F2 V5.0 (hrs)	Bellcore7 V5.0 (hrs)
CPSMC1900 + CPSMP-200	79,071	206,816
CPSMC1900 + CPSMP-210	201,643	479,742

CPSMP-200

Power Input: 100-240 V, 50/60 Hz, 0.62 - 1.5 Amp (typical with a fully-loaded chassis)
Power Output: +12 VDC at 10.83 Amp maximum.

CPSMP-210

Power Input: 48-VDC (38 - 58 VDC) @ 4.0 Amp (typical with a fully-loaded chassis)
Power Output: +12 VDC at 12.5 Amp maximum.

Environment

Tmra*: 0 to 50°C (32 to 122°F) (*Manufacturer's rated ambient temperature)
0 to 60°C (32 to 140°F) (when redundant power or fan module is used)
Storage Temperature: -40 to 80°C (-40 to 176°F)
Humidity: 5 to 95%, non condensing
Altitude: 0 to 10,000 feet

Compliance

EN 55022:1998+A1:2000 Class A; EN 55024:1998; UL Listed;
FCC Part 15 Subpart B; CE Mark; 21 CFR Subpart J

Warranty

Lifetime

Product is certified by the manufacturer to comply with DHHS Rule 21/CFR, Subchapter J applicable at the date of manufacture.

The fiber optic transmitters on this device meets Class I Laser safety requirements per IEC-825/CDRH standards and complies with 21 CFR1040.10 and 21CFR1040.11.

CAUTION: Visible and Invisible Laser Radiation When Open. Do Not Stare Into Beam Or View Directly With Optical Instruments.

CAUTION: Use of controls, adjustments or the performance of procedures other than those specified herein may result in hazardous radiation exposure.

Cable Specifications

Null Modem Cable

The Null Modem Cable is used for connecting a terminal or terminal emulator to the management module's DB-9 connector to access the command-line interface.

The table below shows the pin assignments for the DB9 cable.

Function	Mnemonic	Pin
Carrier Detect	CD	1
Receive Data	RXD	2
Transmit Data	TXD	3
Data Terminal Ready	DTR	4
Signal Ground	GND	5
Data Set Ready	DSR	6
Request To Send	RTS	7
Clear To Send	CTS	8

The table below shows the pin assignments for the RS-232 Null Modem cable:

Chassis Ground	1	—————	1	Chassis Ground
Transmit Data	2	—————	3	Receive Data
Receive Data	3	—————	2	Transmit Data
Request To Send	4	—————	4	Request To Send
Clear To Send	5	—————	5	Clear To Send
Data Set Ready	6	—————	20	Data Terminal Ready
Carrier Detect	8	—————	6	Data Set Ready
Data Terminal Ready	20	—————	8	Carrier Detect
Signal Ground	7	—————	7	Signal Ground

RJ-45 Cable

Category 5:

Gauge:	24 to 22 AWG
Attenuation:	22.0 dB /100m @ 100 MHz
Maximum Cable Distance:	100 meters

- Straight-through **OR** crossover cable may be used.
- Shielded twisted-pair (STP) **OR** unshielded twisted-pair (UTP) may be used.
- Pins 1&2 and 3&6 are the two active pairs in an Ethernet network.
(RJ-45 Pin-out: Pin 1 = TD+, Pin 2 = TD-, Pin 3 = RD+, Pin 6 = RD-)
- All pin pairs (1&2, 3&6, 4&5, 7&8) are active in a Gigabit Ethernet network.
- Use only dedicated wire pairs for the active pins:
(e.g., blue/white & white/blue, orange/white & white/orange, etc.)
- Do not use flat or silver satin wire.

COAX Cable

Coaxial cable media is used for circuits such as DS3, E1 and 10Base-2 Ethernet. The impedance of the coaxial cable is determined by the interface type, for example:

- 75 ohm for DS3.
- 50 ohm for 10Base-2 Ethernet.

Special attention should be given to the grounding requirements of coaxial cable circuits. Installation may require grounding at both cable ends or only one cable end or neither cable end.

Cable Shield Grounding

Media converter network cabling may be shielded or unshielded. Shielded cables **MUST** be grounded according to the specific requirements of the media and port type. For example:

- Shielded RJ-45 cable used for 100Base-Tx Ethernet **MUST** be grounded at both cable endpoints via shielded RJ-45 jacks.
- Shielded RS-232 cable **MUST** have the shield grounded at both cable endpoints via shielded RS-232 connectors.
- COAX cable used for 10Base-2 Ethernet **MUST** only be grounded at a single point.

The media converters provide a jumper option or other grounding mechanism as required. Special attention should be given to the grounding requirements of coaxial cable circuits. Installation may require grounding at both cable ends or only one cable end or neither cable end. See the individual media converter user's guide for cable/port grounding requirements.

Contact Us

Technical Support

Technical support is available 24 hours a day:

United States: **1-800-260-1312**

International: **00-1-952-941-7600**

Transition Now

Chat live via the Web with a Transition Networks Technical Support Specialist.

Log onto **www.transition.com** and click the **Transition Now** link.

Web-Based Seminars

Transition Networks provides 12-16 seminars per month via live web-based training.

Log onto **www.transition.com** and click the **Learning Center** link.

E-Mail

Ask a question anytime by sending an e-mail message to our technical support staff.

techsupport@transition.com

Address

Transition Networks

6475 City West Parkway
Minneapolis, MN 55344, USA

telephone: 952-941-7600

toll free: 800-526-9267

fax: 952-941-2322

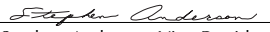
	DECLARATION OF CONFORMITY
Name of Mfg:	Transition Networks 6475 City West Parkway, Minneapolis MN 55344 USA
Model:	PointSystem™ Chassis
Part Number:	CPSMC1900-100, CPSMC1910-100
Regulation:	EMC Directive 89/336/EEC
Purpose: To declare that the PointSystem™ Chassis to which this declaration refers is in conformity with the following standards. EN 55022:1998+A1:2000 Class A; FCC Part 15 Subpart B; UL 1950; 21 CFR Subpart J	
<i>I, the undersigned, hereby declare that the equipment specified above conforms to the above Directive(s) and Standard(s).</i>	
 Stephen Anderson, Vice-President of Engineering	September 14, 2001 Date

Warranty

Limited Lifetime Warranty

Effective for products shipped May 1, 1999 and after. Every Transition Networks' labeled product purchased after May 1, 1999 will be free from defects in material and workmanship for its lifetime. This warranty covers the original user only and is not transferable.

This warranty does not cover damage from accident, acts of God, neglect, contamination, misuse or abnormal conditions of operation or handling, including over-voltage failures caused by use outside of the product's specified rating, or normal wear and tear of mechanical components. If the user is unsure about the proper means of installing or using the equipment, contact Transition Networks' free technical support services.

To establish original ownership and provide date of purchase, please complete and return the registration card accompanying the product or register the product online on our product registration page.

Transition Networks will, at its option:

- Repair the defective product to functional specification at no charge,
- Replace the product with an equivalent functional product, or
- Refund the purchase price of a defective product.

To return a defective product for warranty coverage, contact Transition Networks' technical support department for a return authorization number. Transition's technical support department can be reached through any of the following means:

Technical Support is available 24 hours a day at:

- 800-260-1312 x 200 or 952-941-7600 x 200
- fax 952-941-2322
- email techsupport@transition.com
- live web chat: www.transition.com and click the "Transition Now" link
- voice mail 800-260-1312 x 579 or 952-941-7600 x 579
- All messages will be answered within one hour.

Send the defective product postage and insurance prepaid to the following address:

CSI Material Management Center

c/o Transition Networks

508 Industrial Drive

Waconia, MN 55387 USA

Attn: RETURNS DEPT: CRA/RMA # _____

Failure to properly protect the product during shipping may void this warranty. The return authorization number must be written on the outside of the carton to ensure its acceptance. **We cannot accept delivery of any equipment that is sent to us without a CRA or RMA number.**

The customer must pay for the non-compliant product(s) return transportation costs to Transition Networks for evaluation of said product(s) for repair or replacement. Transition Networks will pay for the shipping of the repaired or replaced in-warranty product(s) back to the customer (any and all customs charges, tariffs, or/and taxes are the customer's responsibility).

Before making any non-warranty repair, Transition Networks requires a \$200.00 charge plus actual shipping costs to and from the customer. If the repair is greater than \$200.00, an estimate is issued to the customer for authorization of repair. If no authorization is obtained, or the product is deemed not repairable, Transition Networks will retain the \$200.00 service charge and return the product to the customer not repaired. Non-warranted products that are repaired by Transition Networks for a fee will carry a 180-day limited warranty. All warranty claims are subject to the restrictions and conventions set forth by this document.

Transition Networks reserves the right to charge for all testing and shipping incurred, if after testing, a return is classified as "No Problem Found."

THIS WARRANTY IS YOUR ONLY REMEDY. NO OTHER WARRANTIES, SUCH AS FITNESS FOR A PARTICULAR PURPOSE, ARE EXPRESSED OR IMPLIED. TRANSITION NETWORKS IS NOT LIABLE FOR ANY SPECIAL, INDIRECT, INCIDENTAL OR CONSEQUENTIAL DAMAGES OR LOSSES, INCLUDING LOSS OF DATA, ARISING FROM ANY CAUSE OR THEORY. AUTHORIZED RESELLERS ARE NOT AUTHORIZED TO EXTEND ANY DIFFERENT WARRANTY ON TRANSITION NETWORKS' BEHALF.

